

# KAWAI

---

Acoustic Piano Recording System PR-1

---

## Owner's Manual

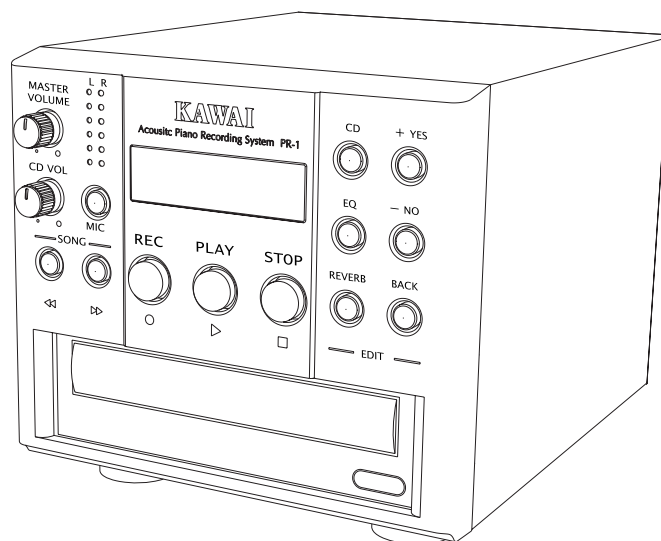

# TABLE OF CONTENTS

<b>SAFETY INSTRUCTIONS</b> .....	1
<b>INTRODUCTION</b> .....	4
<b>SUPPLIED COMPONENT LIST</b> .....	5
<b>PR-1 FEATURES</b> .....	5
<b>EXPLANATION OF COMPATIBLE DISC FORMATS</b> .....	7
<b>QUICK START GUIDE</b> .....	8
<b>CONVENIENT RECORDING FUNCTIONS</b> .....	10
1 Start Timer .....	10
2 START/STOP using a Foot Switch .....	11
3 Changing the Song Number While Recording .....	11
4 Changing the Time Display (Elapsed Time / Remaining Time) .....	12
<b>TIPS AND SUGGESTIONS FOR GETTING A GOOD RECORDING</b> .....	13
<b>PARTS AND NAMES</b> .....	14
<b>BUTTON FUNCTIONS</b> .....	17
1 CD Button .....	17
2 EQ Button .....	21
3 REVERB Button .....	26
<b>PR-1 APPLICATIONS GUIDE</b> .....	28
1 Recording a Piano along with another instrument or vocalist using the MIC setting for the LINE/MIC inputs .....	28
2 Recording a Piano along with another instrument using the LINE setting for the LINE/MIC inputs .....	28
3 Recording a piano along with an External CD Player or Tape Recorder .....	29
4 Recording a Piano in a concert hall .....	29
5 Recording a Piano using different Reverb settings .....	30
6 Record a piano along with another instrument and a vocalist using the line and microphone inputs .....	30
7 Adjusting the sound character of a piano that you are recording using EQ .....	30
8 Using the PR-1 for live sound reinforcement .....	30
9 Using the PR-1 in the studio .....	30
<b>PLAYING BACK A CD USING THE PR-1 OR AN EXTERNAL CD PLAYER</b> .....	31
1 Playing a CD on the PR-1 .....	32
2 Other CD playback functions .....	32
3 Playing a CD recorded using the PR-1 on an External CD Player .....	33
4 Adding reverb to the piano sound without recording .....	33
5 Practicing a Four-hand Performance using the PR-1 to record one of the parts .....	34
6 Playing along with a Karaoke or music minus one CD .....	34
7 Recording other instruments using the PR-1 microphones .....	35
<b>CONNECTING THE PR-1 MICROPHONES TO A GRAND PIANO</b> .....	36
<b>MICROPHONE PLACEMENT GUIDE FOR VARIOUS KAWAI GRAND PIANOS</b> .....	37
<b>CONNECTING THE PR-1 MICROPHONES TO AN UPRIGHT PIANO</b> .....	38
<b>MICROPHONE PLACEMENT GUIDE FOR KAWAI UPRIGHT PIANOS</b> .....	39
<b>TROUBLESHOOTING</b> .....	41
<b>SPECIFICATIONS</b> .....	42

# Important Safety Instructions

## SAVE THESE INSTRUCTIONS

INSTRUCTIONS PERTAINING TO A RISK OF FIRE, ELECTRIC SHOCK, OR INJURY TO PERSONS

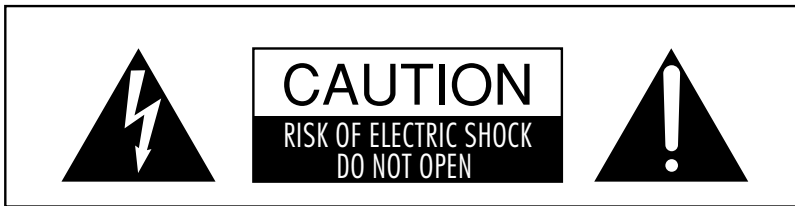

### WARNING

TO REDUCE THE RISK OF FIRE OR ELECTRIC SHOCK, DO NOT EXPOSE THIS PRODUCT TO RAIN OR MOISTURE.

**AVIS : RISQUE DE CHOC ELECTRIQUE - NE PAS OUVRIR.**

TO REDUCE THE RISK OF ELECTRIC SHOCK, DO NOT REMOVE COVER (OR BACK). NO USER-SERVICEABLE PARTS INSIDE. REFER SERVICING TO QUALIFIED SERVICE PERSONNEL.



The lightning flash with arrowhead symbol, within an equilateral triangle, is intended to alert the user to the presence of uninsulated "dangerous voltage" within the product's enclosure that may be of sufficient magnitude to constitute a risk of electric shock to persons.



The exclamation point within an equilateral triangle is intended to alert the user to the presence of important operating and maintenance (servicing) instructions in the literature accompanying the product.

### Examples of Picture Symbols



denotes that care should be taken. The example instructs the user to take care not to allow fingers to be trapped.



denotes a prohibited operation. The example instructs that disassembly of the product is prohibited.



denotes an operation that should be carried out. The example instructs the user to remove the power cord plug from the AC outlet.

Read all the instructions before using the product.

**WARNING - When using electric products, basic precautions should always be followed, including the following.**



**WARNING** Indicates a potential hazard that could result in death or serious injury if the product is handled incorrectly.

The product should be connected to an AC outlet of the specified voltage.



- If you are going to use an AC power cord, make sure that its has the correct plug shape and conforms to the specified power voltage.
- Failure to do so may result in fire.

Do not insert or disconnect the power cord plug with wet hands.

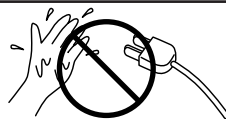

Doing so may cause electric shock.

The chair must be used properly (it must be used only when playing the product).

- Do not play with it or stand on it.
- Only one person is allowed to sit on it.
- Do not sit on it when opening the lid.
- Re-tighten the bolts occasionally.

Doing so may cause the chair to fall over or your fingers to be trapped, resulting in injury.

Do not disassemble, repair or modify the product.

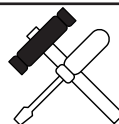
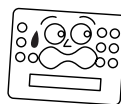

Doing so may result in product breakdown, electric shock or short-circuit.

When using the headphones, do not listen for long periods of time at high volume levels.

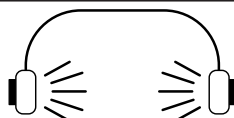

Doing so may result in hearing problems.

When disconnecting the AC power cord's plug, always hold the plug and pull it to remove it.



- Pulling the AC power cord itself may damage the cord, causing a fire, electric shock or short-circuit.

The product is not completely disconnected from the power supply even when the power switch is turned off. If the product will not be used for a long time, unplug the AC power cord from the AC outlet.



- Failure to do so may cause fire in case of lightning.
- Failure to do so may over-heat the product, resulting in fire.

This product may be equipped with a polarized line plug (one blade wider than the other). This is a safety feature. If you are unable to insert the plug into the outlet, contact an electrician to replace your obsolete outlet. Do not defeat the safety purpose of the plug.

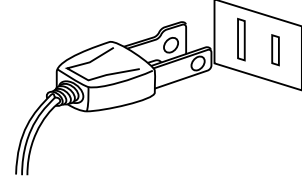

It is a good using to have the PR-1 near the AC outlet and the power cord plug in a position so that it can readily be disconnected in an emergency because electricity is always charging while the plug is in the AC outlet even in a power switch off condition.



## CAUTION

Indicates a potential hazard that could result in injury or damage to the product or other

Do not use the product in the following areas.

- Areas, such as those near windows, where the product is exposed to direct sunlight
- Extremely hot areas, such as near a heater
- Extremely cold areas, such as outside
- Extremely humid areas
- Areas where a large amount of sand or dust is present
- Areas where the product is exposed to excessive vibrations

Using the product in such areas may result in product breakdown. Use the product only in moderate climates (not in tropical climates).

Before connecting cords, make sure that the power to this product and other devices is turned OFF.

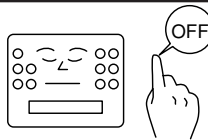

Failure to do so may cause breakdown of this product and other devices.

Take care not to allow any foreign matter to enter the product.

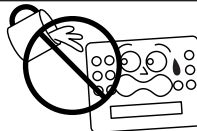

Entry of water, needles or hair pins may result in breakdown or short-circuit. The product shall not be exposed to dripping or splashing. No objects filled with liquids, such as vases, shall be placed on the product.

Do not drag the product on the floor. Take care not to drop the product.

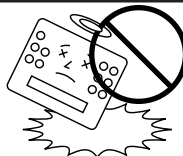

Please lift up the product when moving it. Please note that the product is heavy and must be carried by more than two persons. Dropping the product may result in breakdown.

Do not place the product near electrical appliances such as TVs and radios.

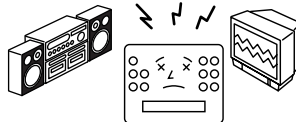

- Doing so may cause the product to generate noise.
- If the product generates noise, move the product sufficiently away from the electrical appliance or connect it to another AC outlet.

When connecting the AC power cord and other cords, take care not to get them tangled.



Failure to do so may damage them, resulting in fire, electric shock or short-circuit.

Do not wipe the product with benzene or thinner.



- Doing so may result in discoloration or deformation of the product.
- When cleaning the product, put a soft cloth in lukewarm water, squeeze it well, then wipe the product.

**Do not stand on the product or exert excessive force.**

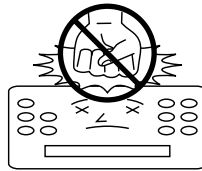

- Doing so may cause the product to become deformed or fall over, resulting in breakdown or injury.

**The product should be located so that its location or position does not interfere with its proper ventilation. Ensure a minimum distance of 5cm around the product for sufficient ventilation. Ensure that the ventilation is not impeded by covering the ventilation openings with items, such as newspaper, table-cloths, curtains, etc.**

**Do not place naked flame sources, such as lighted candles on the product.**

**The product should be serviced by qualified service personnel when:**

- The power supply cord or the plug has been damaged.
- Objects have fallen, or liquid has been spilled into the product.
- The product has been exposed to rain.
- The product does not appear to operate normally or exhibits a marked change in performance.
- The product has been dropped, or the enclosure damaged.

### **Notes on Repair**

Should an abnormality occur in the product, immediately turn the power OFF, disconnect the power cord plug, and then contact the shop from which the product was purchased.

### **CAUTION:**

To prevent electric shock, match wide blade of plug to wide slot, fully insert.

### **ATTENTION:**

Pour éviter les chocs électriques, introduire la lame la plus large de la fiche dans la borne correspondante de la prise et pousser jusqu'au fond.

### **Instruction for AC power cord (U.K.)**

Do not plug either terminal of the power cord to the ground of the AC outlet on the wall.

### **FCC Information**

This equipment has been tested and found to comply with the limits for a Class B digital device, pursuant to Part 15 of the FCC Rules. These limits are designed to provide reasonable protection against harmful interference in a residential installation. This equipment generates, uses and can radiate radio frequency energy and, if not installed and used in accordance with the instructions, may cause harmful interference to radio communications.

If this equipment does cause harmful interference to radio or television reception, which can be determined by turning the equipment off and on, the user is encouraged to try to correct the interference by one or more of the following measures:

- Reorient or relocate the receiving antenna.
- Increase the separation between the equipment and receiver.
- Connect the equipment into an outlet on a different electrical circuit from the receiver.
- Consult the dealer or an experienced radio/TV technician for help.

### **Canadian Radio Interference Regulations**

This instrument complies with the limits for a class B digital apparatus, pursuant to the Radio Interference Regulations, C.R.C., c. 1374.



### **An information on Disposal for users**

If your product is marked with this recycling symbol it means that, at the end of its life, you must dispose of it separately by taking it to an appropriate collection point.

You should not mix it with general household waste. Disposing of this product correctly will prevent potential negative effects on the environment and human health which could otherwise arise due to inappropriate waste handling.

For further details, please contact your local authority.  
(European Union only)

# INTRODUCTION

Thank you for purchasing the Kawai PR-1 Acoustic Piano Recording System. The PR-1 is an integrated microphone and CD audio recorder system specifically designed to make recording an acoustic piano extremely easy, even for a newcomer to audio recording techniques.

In addition to making high quality CD recordings, the PR-1 can be used in a variety of other ways. The PR-1 can be used to record a piano along with other instruments or a vocalist, or as a microphone system in live performances or in a recording studio. You can also use the PR-1 to play along with Karaoke or music minus one CD's using headphones or an amplifier and external speakers, or to add the ambience of a stage or concert hall to your piano when listening through headphones or external speakers.

Please read this manual thoroughly and keep it handy as a reference so that you can get the most out of your PR-1.

# SUPPLIED COMPONENT LIST

Please check to make sure all of the components listed below have been included.

If anything is missing please contact your Kawai dealer to obtain the missing components.

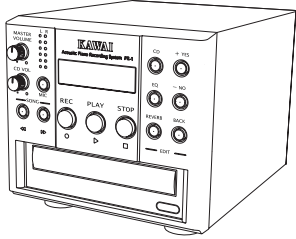
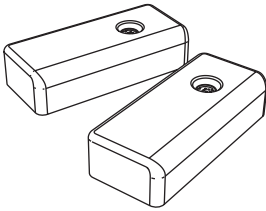
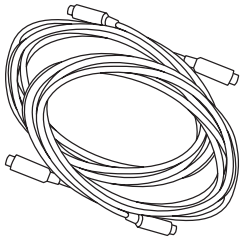
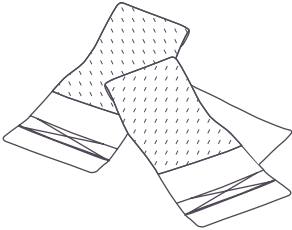
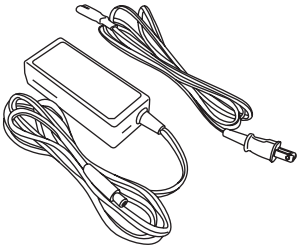
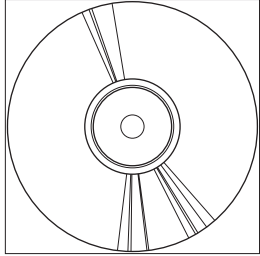
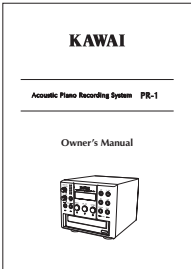
<p>PR-1 main unit 1 pc</p> 	<p>PR-1 custom Piano microphone 2 pcs</p> 	<p>Piano microphone cable 2 pcs</p> 
<p>Attachment band for piano microphone 2 pcs</p> 	<p>AC Adaptor 1 pc</p> 	<p>CD-RW 1 pc</p> 
<p>Owner's Manual 1 pc</p> 		

The supplied AC adaptor was designed specifically for the PR-1. Please do not use this AC Adaptor with any other device.

# PR-1 FEATURES

	Ref. page
<b>1. Record your performance to a CD</b>	pg. 8
① You can add reverb to your performance while recording	Pg. 26
② You can adjust the sound character using the built in EQ while recording	pg. 21
③ You can record other instruments or vocalists along with a piano using the Line/mic inputs.	pg. 28
④ You can record an ensemble of piano, electronic keyboard, and guitar (with pickup). (You are able to connect two cables to external input terminal) You need to switch MIC/LINE	pg. 28
⑤ You can record a piano along with an external CD or tape player that has been connected to the LINE/MIC inputs.	pg. 29
<b>2. The PR-1 can be used to record live performances on a stage or in a concert hall. (Extended length microphone cables are available for use when the main unit must be placed far away from the piano).</b>	pg. 29
<b>3. You can play back and listen to your recorded CD as well as any regular audio CD, including commercial CD's on the PR-1 through headphones or by connecting an amplifier and external speakers to the Line outputs.</b>	pg. 31
<b>4. Playback CD's recorded on the PR-1 on another CD player once the disc has been "Finalized".</b>	pg. 32
<b>5. The PR-1 can be for used as a live microphone system for piano when connected to a PA system.</b>	pg. 33
<b>6. The PR-1 can be used as a piano microphone system in a recording studio or other recording environment when connected to an external recorder.</b>	pg. 34
<b>7. You can add reverb to the piano when using headphones or external speakers to simulate the ambience of a stage or concert hall when you play.</b>	pg. 34
<b>8. You can play a piano along with a recording you have made or with a Karaoke or music minus one CD.</b>	pg. 34
① You record the one part of the four-hand performance in advance and then play the other part of four-hand, while listening to the performance you have just recorded. In this way, you can complete the four-hand performance by yourself.	pg. 35
② You can add reverb to your performance while listening to karaoke CD.	pg. 34
<b>9. The PR-1 is capable of recording instruments other than piano either using the supplied piano microphones or by connecting external microphones to the LINE/MIC inputs. For example, The PR-1 could be used to record vocalists, wind instruments etc.</b>	pg. 34

# EXPLANATION OF COMPATIBLE DISC FORMATS (CD, CD-R, AND CD-RW)

The following three types of discs are compatible with the PR-1 (CD, CD-R, and CD-RW).

Below is a brief description of each type of CD disc.

## <CD>

CD is an abbreviation for Compact Disc.

CD discs contain recorded music or sound. This type of disc is for playback only. The PR-1 can playback this type of disc but this type of disc cannot be used to record music on the PR-1.

## <CD-R>

CD-R is an abbreviation for Compact Disc Recordable.

These discs are recordable but, you cannot erase what you have recorded.

Also, once you finalize the disc (see pg.17) you cannot record to the disc even if there is recording time remaining.

There are two different sizes of CD-R discs.

The recording time for 650MB discs is ... maximum 74 min

700MB discs is ... maximum 80 min

## <CD-RW>

CD-RW an abbreviation for Compact Disc ReWritable.

This disc is also a recordable type but it is possible to erase songs one at a time or to erase all songs. When erasing one song at a time the PR-1 can only erase the last song on the disc. You cannot erase songs from the middle of the song list one at a time.

There are two different sizes of CD-R discs.

The recording time for 650MB discs is ... maximum 74 min

700MB discs is ... maximum 80 min

Below is a chart that shows what you can do with PR-1 and the three types of discs.

	Playing back using PR-1	Record	Erase
CD	O	X	X
CD-R	O	O *1	X
CD-RW	O	O *2	O *3

\*1 : After finalizing (see pg.17), you cannot record anymore.

\*2 : After finalizing (see pg.17), if you unfinalize (see pg.19) you can continue to record until the maximum time limit has been reached.

\*3 : After finalizing (see pg.17), if you unfinalize (see pg.19) you can erase the song.

Note) If you want to listen to the CD-R or CD-RW you have just recorded on another CD player, you need to finalize it first on the PR-1 (see pg.17).

CD's recorded on the PR-1 may not playback on all CD players. This is because certain types of older CD players or CD radio cassette tape recorders cannot play back CD-R or CD-RW discs. CD-R or CD-RW.

# QUICK START GUIDE

Before you begin recording the piano, place the PR-1 on top of the piano or in a place where you can conveniently operate the PR-1 while sitting on the piano bench. Make sure the PR-1 is set horizontally on a flat surface because the PR-1 may not operate properly if it is not level.

Please follow steps ① to ⑪ to make a recording.

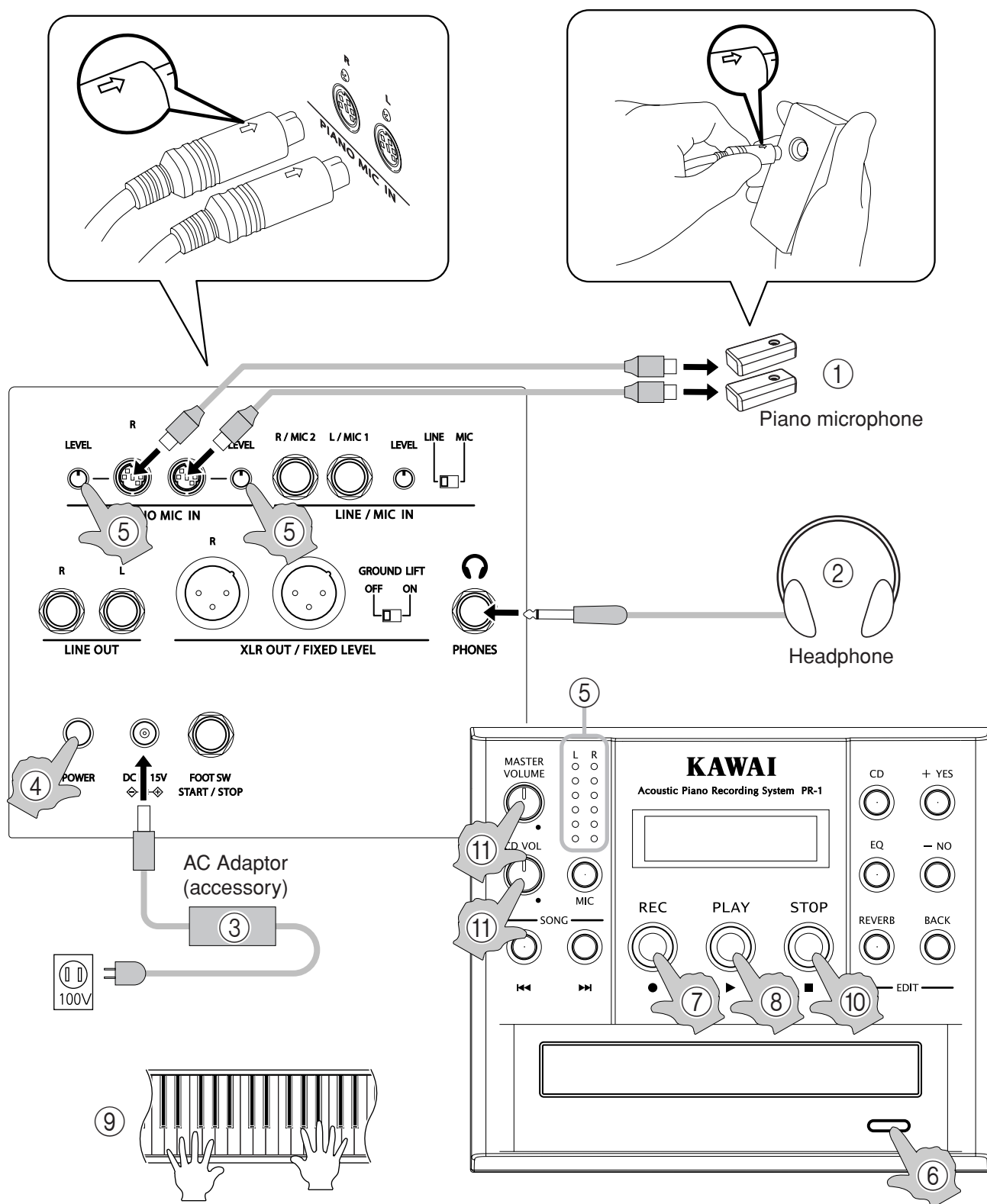

## 1 CONNECTING THE PIANO MICROPHONE

Attach the two supplied piano microphones to your piano and connect them to the PIANO MIC IN jacks on the rear of the PR-1 main unit. See pg.36 to 40 for instructions on how to attach the microphones to the piano and for proper microphone placement.

## 2 CONNECTING THE HEADPHONES

Use headphones to listen to the recorded sound.

## 3 CONNECTING THE POWER SOURCE

Connect the attached AC Adaptor to the PR-1 and plug in the power source to an outlet.

## 4 TURN THE POWER ON

Push the power switch and turn the power on.

## 5 ADJUSTING THE LEVEL OF THE PIANO MICROPHONES

You need to adjust the level of the piano microphones using the The PIANO MIC IN L/R LEVEL knobs on the back panel. Play the piano and watch the L/R level indicator on the front panel. When you play loud with both hands the first red LED should light just for the loudest notes. Adjust the L and R microphone levels to be the same. Play soft and loud and also in different key ranges when setting the microphone levels to make sure that the level will be good regardless of how you play the piano.

## 6 INSERT RECORDABLE CD-R

Press the Open/Close button to open the CD tray. (Pressing the STOP button will also open the tray) Place the CD-R or CD-RW disc in the tray and press the Open/Close button again to close the tray. When you turn on the power, the display will show the following information.



Put the disc in the tray silver side down (the side that doesn't have any writing on it).

SONG 01  
TIME 00:00

## 7 PREPARE FOR RECORDING

Press the REC button.  
The REC button will flash.  
The display will show the following.

SONG 01  
REST 00:00



When the PR-1 is ready to record, the REC button will stop flashing but it will still be lit steadily.



Steady light

## 8 TO START THE RECORDING

Press the PLAY button.

The REC button and PLAY button will both light up and the recording will start.

RECORDING  
REST 00:00

- \* You can use the start timer to delay the recording so the actual recording does immediately start when you press the play button. You can program in a delay to allow time to move your fingers to the keys. The start timer is also useful to prevent too much space at the beginning of the recording while you are moving your fingers to the keys. (see pg.10).
- \* You can also start recording by using the foot switch (see pg.11).

## 9 PERFORMANCE

Play the piano song you want to record.

## 10 STOP THE RECORDING

When the performance is finished, press the STOP button.

SONG 01  
TIME 00:00

The display will show the information above and the PR-1 will be ready to play the song you have just recorded.

## 11 PLAYING BACK THE RECORDED SONG

Press the PLAY button and listen to the recorded song using headphones.

Adjust the playback level to a comfortable volume by setting the CD VOL knob to maximum and then adjusting the MASTER VOLUME knob as desired.

If you want to play this CD on another CD player or CD radio cassette tape recorder, you must first "FINALIZE" the CD.

Please see pg.17 for more detail.

Remember once you finalize a CD-R you cannot Record anymore using that disc. (CD-RW discs can be unfinalized. See pg.18)

## 12 ADD SONGS

If you want to record another song, follow steps ⑦ - ⑩ again.

Once you press the REC button the song number will automatically change to 2 and The PR-1 will record the next song.

PRESS PLAY + REC  
TIME 00:00

# CONVENIENT RECORDING FUNCTIONS

## 1. Start Timer

The Start timer allows you to set a programmable delay between the time you press the PLAY button to start recording and the time the PR-1 actually begins recording. This is useful to prevent too much blank space at the beginning of a recording and to allow you time to move your fingers to the keys after you press the PLAY button.

The timer can be set from OFF to 10 seconds.

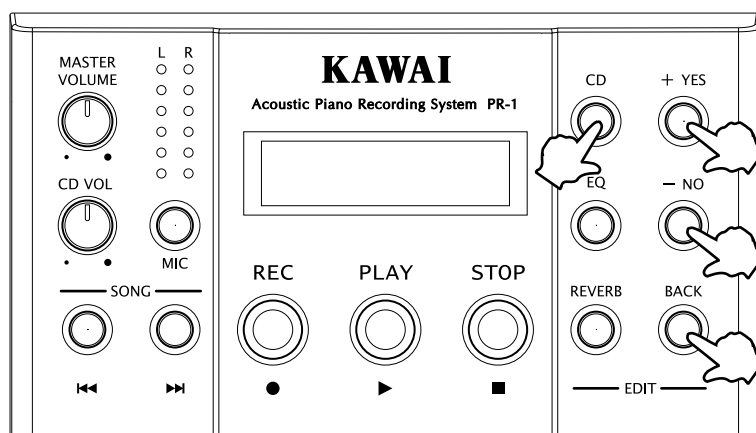

### <Setting the Start Timer>

1. Press CD button five times.

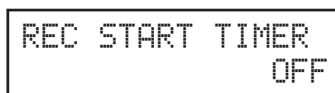

The CD button will light and the display shows the current setting.

2. Use the “+ YES”, “- NO” buttons to set the delay time in seconds, OFF, 1, 2, .... 10.

The display shows the delay time has been set to 5 seconds.

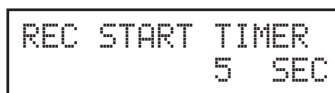

Press the BACK button to return to the first screen. Press REC button to prepare for recording.

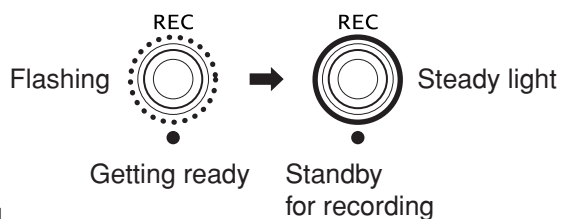

Press the PLAY button when you are ready to record.

The PLAY button lamp will flash and you can see that the timer is counting.

(The display will show the countdown)

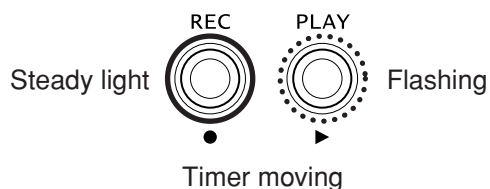

Then the display will change from 5 seconds, 4 seconds, 3 seconds... and when it gets to 0 seconds, the PLAY button lamp will immediately light up and the recording will start.

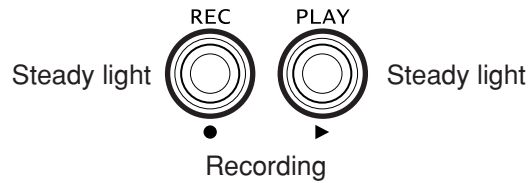

## 2. START/STOP by a Foot Switch

If you connect the optional F1, F1-r (which is sold separately) foot switch to the rear panel FOOT SW START/STOP jack, you can start recording by pressing the foot switch instead of pressing the PLAY button. You can use the Start Timer along with the footswitch if you want to.

If you press the foot switch while recording, it is the same as pressing the STOP button. The recording will stop immediately. You can also use the foot switch to play/stop a normal CD.

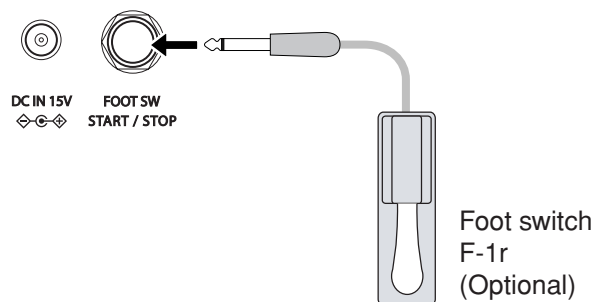

## 3. Changing the Song Number While Recording without stopping the recording

Normally when recording multiple songs using the PR-1, when you finish recording one song, you must press the STOP button then begin the recording procedure again to change the song number to the next song. Some times it is not desirable to stop recording but it is desirable to divide a particular song or performance into more than one song number. For example, when recording piano sonata's first and second movement together you might want to have different song number for each movement, but you do not want to stop the performance just to change song numbers. In this situation, while you are still recording (REC and PLAY buttons are lit), press REC button once again and the song number will advance to next song number and keep on recording.

Please be aware when you press the REC button, there will be a few seconds of blank time.



Press the REC button.

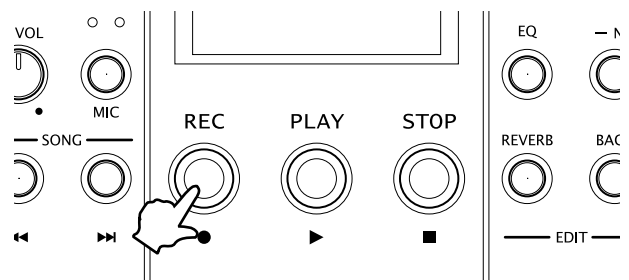

The song number will change and the REC and PLAY button will both flash for few seconds. When the buttons are flashing, the recording won't start. When both button light up steadily, the next song is recording.

## 4. Changing The Time Display (Elapsed time ↔ Remaining time)

When recording/playing a CD, you can change the time display to elapsed time or remaining time.

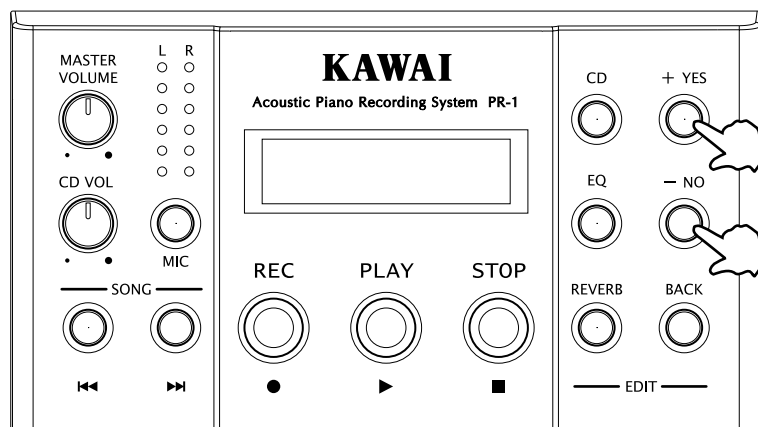

Turn the power on and the display will show the following information.

```
SONG 01  
TIME 00:00
```

While recording, the display will display the following information.

```
RECORDING  
TIME 00:01
```

The display shows the Elapsed time for the current song in minutes and seconds. "TIME 00:00"

Pressing the "+ YES", "- NO" buttons changes the time display to show remaining time on the disc.

```
SONG 01  
REST 08:00
```



You can see that 8 minutes remain on this disc.

```
RECORDING  
REST 64:10
```

This display shows that this disc has 64 minutes and 10 seconds left to record. The disc does not memorize the detail of the time display.

# TIPS AND SUGGESTIONS FOR GETTING A GOOD RECORDING

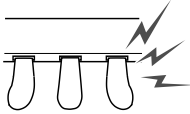
Here are a few tips and suggestions to help you to make the best recordings possible with the PR-1.

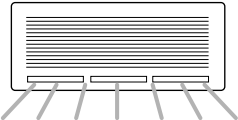
<p><b>1</b></p>	<p>Make sure the bench you are using is free of squeaks or other noises that might affect the quality of the recording. Remember the microphones are very sensitive and can pick up unwanted noises.</p>	
<p><b>2</b></p>	<p>When recording at home, be sure to place the microphones on the back side of the piano, close to the soundboard (see pg.36 - 40 for information on proper microphone placement guidelines). Since the microphones are very close to the piano you can hear any pedal noise very clearly. If you simply step on the pedal, the sound of the pedal may be very loud through the microphones so it is better to step the pedal very gently but firmly if possible to reduce extraneous pedal noise. If you still hear pedal noise you may want to have a piano technician adjust your piano to reduce extraneous noises or creaks. In some cases you can reduce or eliminate the pedal noise by adjusting the EQ (see pg.21).</p>	
<p><b>3</b></p>	<p>If the recording level is set too high, any great performance will be distorted and sound bad. If you are hearing distortion adjust the piano microphone's LEVEL knob until the first red LED on the L/R level indicator on the front panel lights when you play the loudest passage in the song. If you are playing loudly and the first red LED does not light on the level indicator even with the piano microphone LEVEL knobs set to maximum PR-1 this is the optimum setting and the PR-1 will make a good recording.</p>	
<p><b>4</b></p>	<p>Using reverb when recording can enhance the sound quality of the recording but, if the reverb is set too deep, the performance may sound unclear and not professional. Be very careful when you add reverb to your recordings. As a general rule, less is more.</p>	
<p><b>5</b></p>	<p>To ensure that you get the best possible recording we recommend that you have your piano tuned before making any important recordings.</p>	
<p><b>6</b></p>	<p>Because the PR-1 piano microphones are placed below the piano it makes no difference whether the lid is open or closed when you record with the PR-1.</p>	
<p><b>7</b></p>	<p>The PR-1 system is designed to avoid recording extraneous noises that might occur during recording but the microphones are very sensitive so it is possible that loud noises will be "heard" by the microphone and recorded. Try to keep the room where you are recording as quiet as possible during the recording. Even in professional recording studios noise from air conditioners, gardeners, low flying airplanes, and other environmental sources can mar an otherwise good recording. Try to record at a time when these types of noises can be kept to a minimum.</p>	

# PARTS AND NAMES

## FRONT PANEL

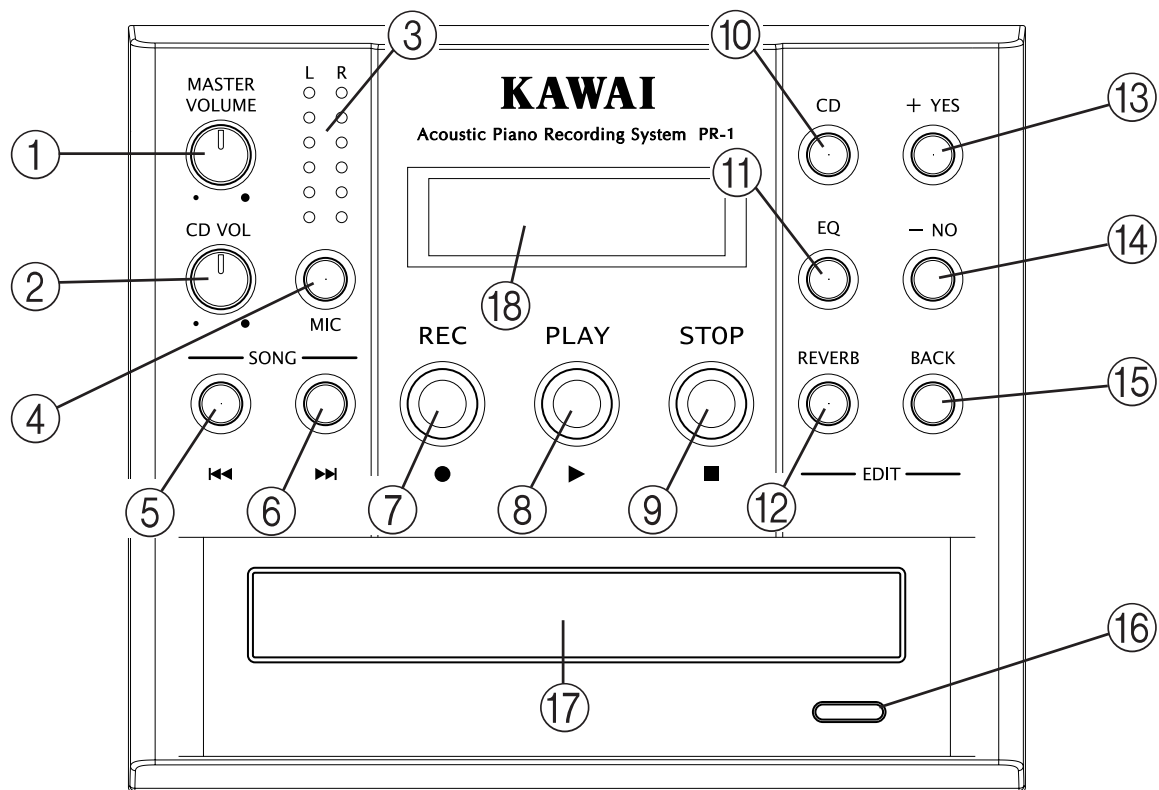

### ① MASTER VOLUME

This volume knob adjusts the sound level or signal level for the LINE OUTPUTS. This volume knob can also be used to balance the volume of any devices or microphones connected to the LINE INPUTS. This volume knob does not affect the recording level.

### ② CD VOL

This volume knob adjusts the sound level or signal level for the CD only. This knob can be used to balance the volume of the CD with other instruments or devices that connected to the LINE INPUTS. This knob can also be used to adjust the volume of the CD when you are playing along with a Karaoke or music minus one CD.

### ③ LEVEL indicator L/R

This level indicator shows the recorded sound level (signal level) of the CD. This indicator also shows the total sound level from the piano microphones and of any instruments or microphones that are connected to LINE/MIC IN jacks. Use this indicator to set the proper input levels for the piano microphones and the LINE/MIC INPUTS. Set the appropriate input levels so that

the first red LED on the indicator lights occasionally with the loudest sounds. This is the best setting for optimal recording performance. If the first red LED is constantly lit or the second is lighting in loud sections the recording will be distorted because the input levels are too high. If the first red LED does not light during the loudest playing even when the appropriate LEVEL knobs are set to maximum this is OK and the PR-1 will make a good recording.

### ④ MIC switch

This button is used to mute or unmute the piano microphones. When the button is lit the piano microphones are active. When you are playing back a CD using external speakers connected to the PR-1 if you are not using the piano microphones it is a good idea to mute them to avoid any feedback through the speakers.

### ⑤⑥ 5/6 Select SONG (Forward, rewind, beginning of the song)

These buttons are used to select the different songs when playing a CD. ⑤ selects The previous song number and ⑥ selects the next song.

If you press ⑤ while a CD is playing, it goes back to the beginning of the song. If you press ⑤ once again, it goes back to the previous song. If you press and hold ⑤, it will rewind and ⑥ will fast forward the song. When rewinding or forwarding the song, the PLAY button will flash quickly. You can fast forward or rewind when the song is not playing, too.

## ⑦ REC

When you press REC button, the button will light and the PR-1 will standby for recording. If you press this button while piano microphone's switch is off, it will be automatically turned on and ready to record. If you do not want to record the sound from piano microphone, you can turn the MIC switch off while in standby mode. Also, while recording, you don't have to press STOP button to change the song number. All you need to do is to press the REC button again while recording and it automatically changes the song number.

## ⑧ PLAY

This button will start playing the CD. When it is in standby mode for recording, the PLAY button is used to start the recording. When you playback the CD, only the green LED will light. Both green and red LED's will light when it is recording. When the start timer is set (see pg.10), the green LED will flash. After the start timer counts down the Play button will stop flashing and light steadily and start the recording.

## ⑨ STOP

This button is used to stop the CD or to stop the recording.

If you press the STOP button while recording, it goes back to the beginning of the song you were recording. If you press the PLAY button, the recorded performance will be played.

## ⑩ CD

This button has a menu of various parameters related to recording and playing a CD (see pg.17). If you press the CD button, the button will light up and the first parameter screen will be displayed.

Pressing this button repeatedly will take you through the menu. Use the + YES, – NO buttons to adjust the value for the selected parameter. When you are finished, press the BACK button to return to the main screen.

## ⑪ EQ

This button has a menu of various parameters related

to adjusting the sound character of the piano microphones and the LINE/MIC INPUTS (see pg.21). If you press the EQ button, the button will light up and the first parameter screen will be displayed. Pressing this button repeatedly will take you through the menu. Use the + YES, – NO buttons to adjust the value for the selected parameter. When you are finished, press the BACK button to return to the main screen.

## ⑫ REVERB

You can add reverb to your piano or microphone and other instruments which are connected (see pg.26). If you press the REVERB button, the button will light up and the first parameter screen will be displayed. Use the + YES, – NO buttons to adjust the value for the selected parameter. Pressing this button repeatedly will take you through the menu. Use the + YES, – NO buttons to adjust the value for the selected parameter. When you are finished, press the BACK button to return to the main screen.

## ⑬⑭ + YES, – NO

These buttons are used to answer “yes” and “no” and to adjust the values for the various parameters in the button menus. The + YES button increases the value and is used to answer “yes”. The – NO button decreases the value or is used to answer “no”. Pressing these buttons while main screen is displayed, switches the time display between <elapsed time ↔ remaining time> (see pg.12).

## ⑮ BACK

This button is used exit the various button menus after you finish adjusting the settings. Push The BACK button to go back to the CD play screen.

## ⑯ CD TRAY OPEN/CLOSE button \*

This button is used to open/close the ⑰ CD tray automatically.

## ⑰ CD TRAY

Carefully place the CD on top of the tray. Put the CD in the center of the tray and press the ⑯ button and close the tray. Please hold the CD's center hole and outer edge carefully with fingers and do not touch the bottom part of the CD.

\* When the CD tray is open, you can press the ⑧ PLAY button or the ⑨ STOP button to close the tray.

\* If you press the STOP button for few seconds, it also closes the tray.

## ⑱ LCD DISPLAY

# REAR PANEL

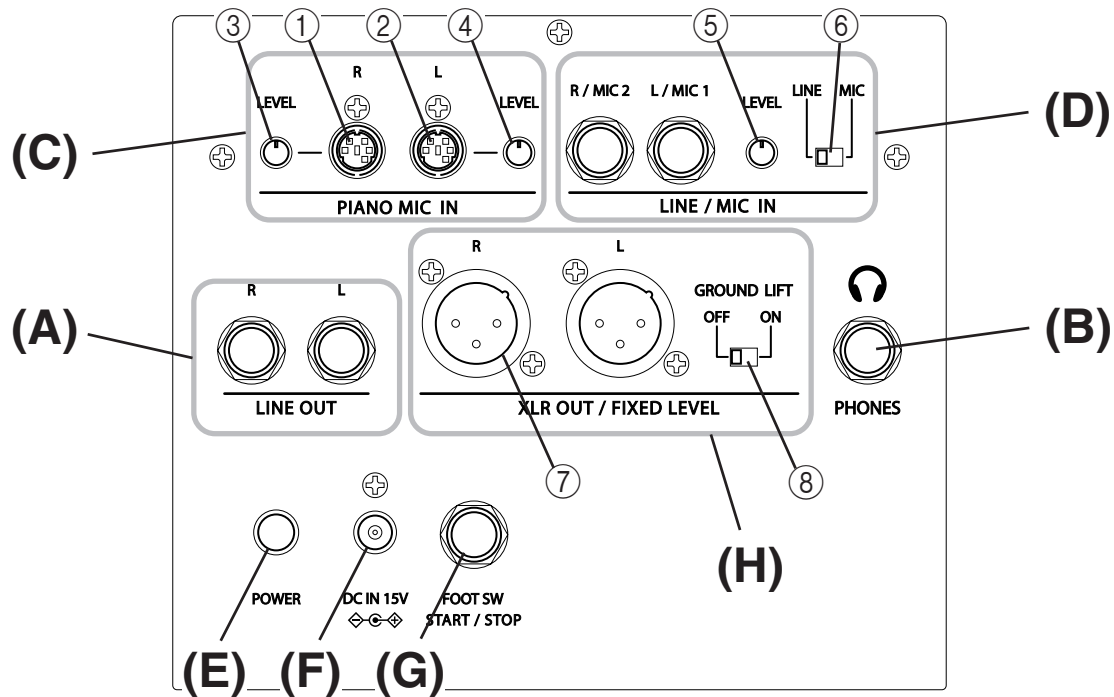

## (A) LINE OUT

These 1/4" jacks output the sound from the piano microphones plus the sounds from any devices that are connected to the LINE/MIC INPUTS. Use these jacks to connect the PR-1 to external speakers, PA system or other device. The Master VOLUME knob DOES affect these outputs.

## (B) PHONES

This jack is used to connect a set of headphones.

## (C) PIANO MIC IN

These jacks are used to connect the PR-1's piano microphones. Please use the supplied cables to connect the microphones. Use the LEVEL knob next to R and L to adjust the microphone's recording level. ③ adjusts the R (right) microphones, ④ adjusts the L (left) microphone level.

## (D) LINE/MIC IN

Use these jacks to connect external instruments (electric keyboard or pick-up guitar) or microphones. Anything you connect to these jacks can also be recorded to the CD.

Even though there are two jacks they do not need to be used only as stereo inputs. They can be used to connect two different mono sources such as a guitar to one jack and a microphone to the other. Press the EQ button to access that menu and adjust the settings for these jacks (see pg.23 for more detail).

Use the ⑤ LEVEL knob to adjust the input level for both jacks. Use headphones to listen and make sure the volume level is correct.

Use the level indicator on the front panel to adjust the signal level for the best sound.

When you connect a microphone switch the ⑥ LINE/MIC sensitivity switch to MIC. When you use CD player, pick-up guitar or keyboard, switch it to LINE.

If nothing is connected to the LINE/MIC inputs to prevent the noise, set the LINE/MIC sensitivity switch to LINE and set the LEVEL knob to 0.

## (E) POWER

Push the POWER button to turn the PR-1 on. Turn the power off when the PR-1 is not in use.

## (F) DC IN 15V

Use this jack to connect the supplied power adaptor to the PR-1.

Please do not use any adaptor other than the supplied adaptor to avoid damage to the PR-1 or the adaptor. Please unplug the PR-1 if you will not be using it for a long period of time.

## (G) FOOT SW START/STOP

Connect the F1, F-1r foot switch which is sold separately.

Use the connected pedal to start/stop the recording or playback of the CD.

## (H) XLR OUT / FIXED LEVEL

### ⑦ R, L OUTPUTS

These XLR jacks output the sound from the piano microphones plus the sounds from any devices that are connected to the LINE/MIC INPUTS. Use these jacks to connect the PR-1 to external speakers, PA system or other device. The Master VOLUME knob DOES not affect these outputs. The CD VOL knob (CD player) and the EQ settings (piano sound) DO affect these outputs.

### ⑧ GROUND LIFT SW

There is a ground lift switch for the XLR jacks. Normally this switch should be left in the OFF position. In the event of ground loop noise set the GROUND LIFT switch to ON.

# BUTTON FUNCTIONS

All of the parameters and functions used for editing and adjusting the various PR-1 settings have been organized into three main menus assigned to the CD, EQ, and REVERB buttons. This section of the manual will explain these parameters and functions in detail.

## 1. CD Button Menu

- \* Press CD button. The button will light and the various parameters in the CD menu will be displayed.
- \* Press the CD button repeatedly to advance through the menu.
- \* To change the value for the selected parameter, press “+ YES”, “- NO” button.
- \* When you are finished making your settings, press the BACK button to go back to main screen. The CD button light will turn off.

The following parameters are assigned to the CD button.

- 1) FINALIZE THE CD
- 2) ERASE THE LAST SONG RECORDED (CD-RW)
- 3) ERASE ALL SONGS (CD-RW)
- 4) UNFINALIZE THE CD-RW
- 5) START TIMER
- 6) PITCH OF CD (fine tuning of pitch)
- 7) REPEAT
- 8) LANGUAGE SETTING
- 9) FACTORY RESET

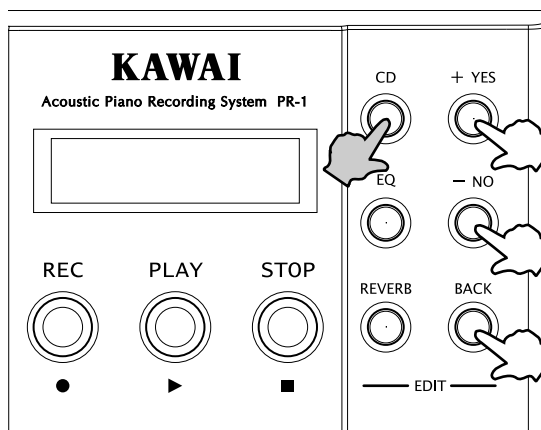

### 1) FINALIZE THE CD

Before you can play a CD-R or CD-RW disc on a conventional CD player you must first finalize the disc. Once you finalize a CD-R you cannot record any more music on the disc regardless of how much time may remain available on the disc.

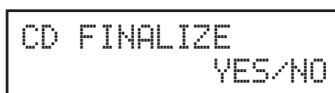

Press the CD button. The button will light and the display will show the following information.

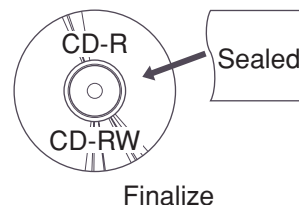
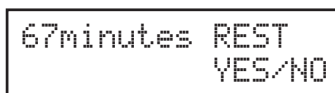

If you want to finalize the disc, press the “+ YES” button.

The display will show the remaining time (in minute) that is recordable in the CD-RW and the PR-1 will ask if you really want to finalize.

If you are sure you want to finalize the disc, press the “+ YES” button again.

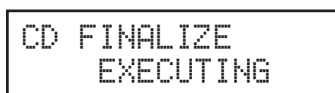

Display while finalizing

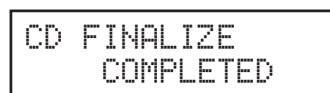

Display once finalizing is completed

Note 1) CD's recorded on the PR-1 may not playback on all CD players even after they have been finalized. This is because certain types of older CD players or CD radio cassette tape recorders cannot play back CD-R or CD-RW discs.

Note 2) Finalizing a disc can take up to several minutes. This is normal.

## 2) ERASE THE LAST SONG RECORDED (CD-RW)

With CD-RW discs you can erase the very last song that is recorded. Here, we are going to erase the last song recorded on CD-RW.

Press the CD button two times. The button will light and the display will show the following information.

```
LAST SONG DELETE
                YES/NO
```

If you want to erase the last song on the disc, press the “- YES” button.

```
LAST SONG DELETE
SURE?          YES/NO
```

The PR-1 will ask you again if you really want to erase it, Press the “+ YES” button to erase the song.

```
LAST SONG DELETE
EXECUTING
```

Display while erasing

```
LAST SONG DELETE
COMPLETED
```

Display once the song is erased

Once you erase a song on a CD-RW, that space on the disc is available again and you can record another song any time.

Note) It may take few minutes to erase a song.

## 3) ERASE ALL SONGS (CD-RW)

With CD-RW discs you can erase all of the songs on a disc.

Press the CD button three times. The button will light and the display will show the following information.

```
ALL SONG DELETE
                YES/NO
```

If you want to erase all of the songs, press the “+ YES” button.

```
ALL SONG DELETE
SURE?          YES/NO
```

The PR-1 will ask if you really want to erase them, Press the “+ YES” button to erase all of the songs.

```
ALL SONG DELETE
EXECUTING
```

Display while erasing

```
ALL SONG DELETE
COMPLETED
```

Display once the songs are erased

Note) Regardless of how many songs are recorded on a disc, it will take 20 minutes to erase all the songs.

## 4) UN-FINALIZE THE CD-RW

After finalizing a CD-RW disc you may want to add more songs or eliminate some songs. In order to do this you must “un-finalize” the disc.

Press the CD button four times. The button will light and the display will show the following information.

```
CD-RW UNFINALIZE
        YES/NO
```

If you want to un-finalize the disc, press the “+ YES” button.

```
CD-RW UNFINALIZE
SURE?      YES/NO
```

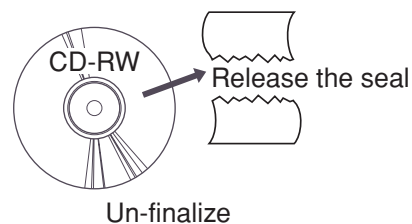

The PR-1 will ask if you really want to un-finalize the disc, Press the “+ YES” button to un-finalize.

```
CD-RW UNFINALIZE
        EXECUTING
```

Display while un-finalizing

```
CD-RW UNFINALIZE
        COMPLETED
```

Display once un-finalizing is complete

Note) It will take few minutes to un-finalize.

## 5) START TIMER (also see pg.10 “Convenient function”).

See pg.10 “Convenient function”.

The Start timer allows you to set a programmable delay between the time you press the PLAY button to start recording and the time the PR-1 actually begins recording. This is useful to prevent too much blank space at the beginning of a recording and to allow you time to move your fingers to the keys after you press the PLAY button.

When the Start Timer is active, after pressing the PLAY button when the recording is in standby mode, the display will automatically show the time until the recording starts.

```
REC START TIMER
                OFF
```

Press the CD button five times. The button will light and the display will show the following information.

Set the value with the “+ YES”, “-NO” buttons. The value will be shown in the bottom right corner of display. The timer can be set from OFF to 10 seconds.

## 6) PITCH OF CD (fine tuning of pitch)

There may be times when it is useful to be able to adjust the pitch of the CD. This function is useful to match the tuning of a pre-recorded CD to the tuning of your piano. The PR-1 allows you to adjust the pitch of a CD.

Press the CD button six times. The button will light and the display will show the following information.

```
CD PLAY PITCH
                0
```

Set the value with the “+ YES”, “-NO” buttons. The value will be shown in the bottom right corner of display. You can adjust the pitch of the CD up or down within a range of  $-7$  to  $+7$ .

If you set the pitch to  $-7$ , it will be approximately 50 cents lower (half of half note) and  $+7$  will sound approximately 50 cents higher.

In some cases while adjusting the pitch, some noise may occur while listening to a CD.

## 7) REPEAT

When you play a CD, if you only want to repeat one song, select “1 SONG”. If you want to repeat from beginning to the end of the CD, select “WHOLE SONG”.

Press the CD button seven times. The button will light and the display will show the following information.

```
REPEAT
      ONE SONG
```

Set the value with the “+ YES”, “- NO” buttons. The value will be shown in the bottom right corner of display. You can select the following repeat settings, OFF – 1 SONG – WHOLE SONG. If you select OFF, the PR-1 will play the CD from the beginning to the end and then stop.

## 8) LANGUAGE SETTING

You can change the display language from English to Japanese.

Press the CD button eight times. The button will light and the display will show the following information.

```
LANGUAGE ｶﾞﾝｺﾞ
      ENGLISH ﺇﾝｺﾞ
```

Select the language, with the “+ YES” or “- NO” buttons.

```
ｶﾞﾝｺﾞ LANGUAGE
      ﺇﾝｺﾞ JAPANESE
```

## 9) FACTORY RESET

If you want to reset the PR-1 back to the factory default settings, press the CD button nine times. The button will light and the display will show the following information.

```
FACTORY RESET
      YES/NO
```

If you want to reset the PR-1, press the “+ YES” button.

```
FACTORY RESET
SURE?      YES/NO
```

The PR-1 will ask if you really want to reset, Press the “+ YES” button.

```
FACTORY RESET
      EXECUTING
```

```
FACTORY RESET
      COMPLETED
```

The factory reset is complete.

After finishing making any settings from the CD button menu, press the BACK button to go back to the main screen.

## 2. EQ Button Menu

- \* Press EQ button. The button will light and the various parameters in the EQ menu will be displayed.
- \* Press the EQ button repeatedly to advance through the menu.
- \* To change the value for the selected parameter, use the “+ YES”, “– NO” buttons.
- \* When you are finished making your settings, press the BACK button to go back to main screen. The EQ button light will turn off.

The following parameters are assigned to the EQ button.

- 1) EQ SETTING
- 2) PIANO PANORAMA
- 3) PIANO NOISE GATE
- 4) LINE IN/MIC. TREBLE
- 5) LINE IN/MIC. BASS
- 6) LINE L/MIC.1
- 7) LINE R/MIC.1
- 8) LINE/MIC IN NOISE GATE
- 9) ANTI-FEEDBACK
- 10) SWITCH LINE OUT PHASE

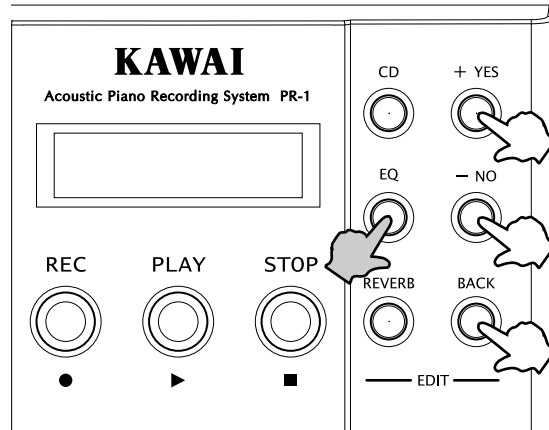

### 1) EQ SETTING

The sound character can be adjusted for any sound or signal that is recorded from the piano microphones or from the LINE/MIC INPUT jacks using the PR-1’s built in EQ. (The PR-1 EQ cannot be used to adjust the sound character of a CD that is already recorded).

The EQ can be used to adjust the tone character of a particular sound to your taste.

Press the EQ button. The button will light and the display will show the following information.

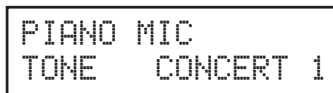

The first EQ setting will be CONCERT 1.

The PR-1 has 10 different preset EQ settings that adjust the sound character of the piano microphones. Experiment with the 10 different settings by listening to each one with headphones or external speakers to find the best setting.

Use the “+ YES” or “– NO” buttons to select the desired EQ setting.

The specific settings for each preset EQ are as described in the table below.

Preset	Description	TREBLE	MID	BASS
Concert 1	Rich BASS and deep MIDDLE sound	-10	+5	+3
Concert 2	MID and TREBLE frequencies are more clear compared to Concert 1	-4	-5	0
Concert 3	This setting produces a clear but softer sound than Concert 2	-10	-8	-3
Concert 4	With this setting, sound projection is emphasized	-4	-4	-4
Concert 5	BASS is raised compared to Concert 4, emphasizing sound transmission	-5	-1	+3
Studio 1	Dynamic BASS and clear TREBLE	+3	-3	+5
Studio 2	BASS/TREBLE are emphasized more than Studio 1	+5	-8	+6
Studio 3	BASS/TREBLE are emphasized even more than Studio 2	+10	-10	+8
Studio 4	BASS is reduced for better blending with an ensemble	+8	-10	-8
Studio 5	For use with more unique ensembles than Studio 4	+7	-3	-12
User	Use this setting if you want a flat unaltered EQ setting. When user is selected, you can also set the TREBLE/MID/BASS EQ bands within a range of -12 to +12).	0	0	0

If you want to create your own EQ setting, select “USER”. You can adjust the BASS/MIDDLE/TREBLE frequency bands individually to your taste. After you select USER, press the EQ button again to select the BASS/MIDDLE/TREBLE bands.

```
PIANO MIC
TONE      USER
```

These settings will be memorized even when you turn the power off.

### 1-1) PIANO TREBLE/MIDDLE/BASS (These parameters only appear when you select USER)

Select USER and press the EQ button. You can adjust the BASS/MID/TREBLE frequency bands individually by using the “+ YES”, “– NO” buttons within a range of –12 to +12. Negative values reduce the volume of the selected band and positive values increase the volume of the selected band. Keep on pressing the EQ button to select the different bands.

```
PIANO MIC
TREBLE    0
```

You can adjust the higher frequencies for the piano mics by using the “+ YES”, “– NO” buttons within a range of –12 to +12. Negative values reduce the volume and positive values increase the volume of selected band.

```
PIANO MIC
MIDDLE    +2
```

You can adjust the middle frequencies for the piano mics by using the “+ YES”, “– NO” buttons within a range of –12 to +12. Negative values reduce the volume and positive values increase the volume of the selected band.

```
PIANO MIC
BASS      +2
```

You can adjust the lower frequencies for the piano mics by using the “+ YES”, “– NO” buttons within a range of –12 to +12. Negative values reduce the volume and positive values increase the volume of the selected band.

Note) After adjusting treble, middle, and bass, please check the recording level. When you set the EQ bands to positive settings it may cause the signal level to be too high and cause distortion.

## 2) PIANO PANORAMA

Panorama sets the width of the stereo image for the piano microphones. With the PR-1, you can record a piano with two piano microphones (left and right). Piano Panorama allows you to adjust where the signal from each microphone will be placed in the stereo field. You can adjust the settings to provide an extreme left and right stereo image or you can adjust the Panorama so the stereo image is more centered.

Press the EQ button two times. (If you selected USER EQ, press the EQ button five times). The button will light and the display will show the following information.

```
PIANO PANORAMA
L8-R8
```

Set the value with the “+ YES”, “– NO” buttons.

The value changes from (L10 – R10), (L9 – R9), (L2 – R2), (L1 – R1), CENTER. If you select L10 – R10, the stereo image will be at its widest point and the left and right microphone signals will be completely separated, left and right. As you select smaller values the stereo image will become more centered. When Piano Panorama is set to CENTER, the stereo image will be completely centered and the same sound will come from both speakers or both sides of the headphones.

### 3) PIANO NOISE GATE

The Noise Gate can be set so the PR-1 does not record soft sounds that are below a set volume level from the piano microphones. This can be useful for eliminating undesirable background noises.

Press the EQ button three times. (If you selected USER EQ, press the EQ button six times). The button will light and the display will show the following information.



Set the value with the "+ YES", "- NO" buttons. You can select any value between (OFF to 10). The higher the value the more noise will be eliminated or cut. At higher settings it is possible that the noise gate will cut off some of the softer piano notes so be careful when setting the noise gate. Settings between 2 – 5 are usually good for piano.

### 4) LINE IN/MIC. TREBLE

You can adjust the higher frequencies for instruments and microphones that are connected to LINE/MIC input.

Press the EQ button four times. (If you select USER EQ, press the EQ button seven times). The button will light and the display will show the following information.

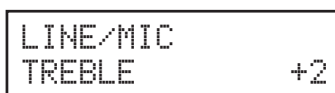

Set the value with the "+ YES", "- NO" button. You can adjust the TREBLE frequencies within a range of -12 to +12. Negative values reduce the volume and positive values increase the volume of the selected band.

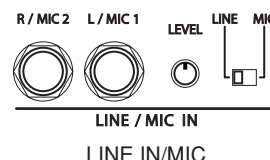

### 5) LINE IN/MIC. BASS

You can adjust the lower frequencies for instruments and microphones that are connected to LINE/MIC input.

Press the EQ button five times. (If you select USER EQ, press the EQ button eight times). The button will light and the display will show the following information.

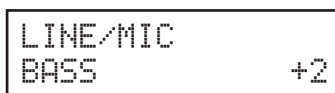

Set the value with the "+ YES", "- NO" button. You can adjust the BASS frequencies within a range of -12 to +12. Negative values reduce the volume and positive values increase the volume of the selected band.

Note) After adjusting treble and bass, please check the recording level. When you set the EQ bands to positive settings it may cause the signal level to be too high and cause distortion.

### 6) LINE L/MIC.1

You can adjust the panning of instruments or microphones that are connected to LINE L/MIC.1 input.

Press the EQ button six times. (If you select USER EQ, press the EQ button nine times). The button will light and the display will show the following information.

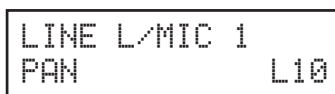

Set the value with the "+ YES", "- NO" buttons. you can set the panning for the LINE L/MIC IN input to the following values (L10 – L1, CENTER, R1 – R10). Setting the pan to L10 places the sound completely in the left speaker, CENTER places the sound in the center, and R10 places the sound completely in the right speaker.

## 7) LINE R/MIC.2

You can adjust the panning of instruments or microphones that are connected to LINE R/MIC.2 input.

Press the EQ button seven times. (If you select USER EQ, press the EQ button ten times). The button will light and the display will show the following information.

```
LINE R/MIC 2
PAN          L10
```

Set the value with the “+ YES”, “- NO” buttons. you can set the panning for the LINE R/MIC IN input to the following values (L10 – L1, CENTER, R1 – R10). Setting the pan to L10 places the sound completely in the left speaker, CENTER places the sound in the center, and R10 places the sound completely in the right speaker.

## 8) LINE/MIC IN NOISE GATE

The Noise Gate can be set so the PR-1 does not record soft sounds that are below a set volume level from the LINE/MIC IN inputs. This can be useful for eliminating undesirable background noises.

Press the EQ button eight times. (If you selected USER EQ, press the EQ button eleven times). The button will light and the display will show the following information.

```
LINE/MIC
NOISE GATE   3
```

Set the value with the “+ YES”, “- NO” buttons. You can select any value between (OFF to 10). The higher the value the more noise will be eliminated or cut. At higher settings it is possible that the noise gate will cut off some of the desirable sounds from the LIEN/MIC IN inputs so be careful when setting the noise gate.

## 9) ANTI-FEEDBACK

Feedback sometimes will occur when the volume of connected external speakers is very loud or when you record using the piano microphones with external speakers connected.

If feedback occurs under these conditions set ANTI-FEEDBACK to ON to reduce this type of feedback (It does not completely eliminate feedback in all cases)

Press the EQ button nine times. (If you selected USER EQ, press the EQ button twelve times). The button will light and the display will show the following information.

```
ANTI-FEEDBACK
OFF
```

Set the value with the “+ YES”, “- NO” buttons. You can select (OFF, ON). If you set ANIT-FEEDBACK to ON, the sound coming out of the external speakers may sound a little different.

The recorded piano sound going to a CD is not affected by the ANTI-FEEDBACK setting.

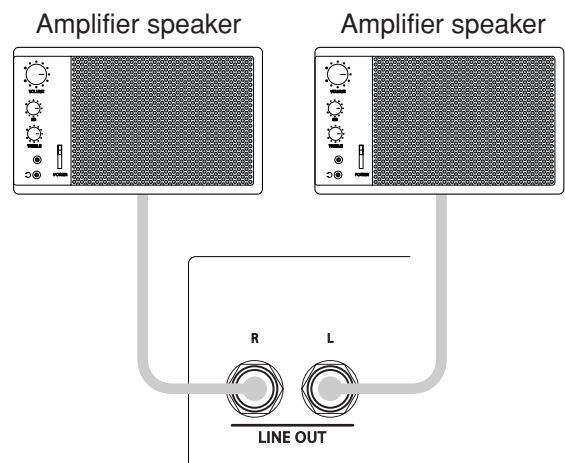

## 10) LINE OUT PHASE INVERT

Inverting the phase of the PR-1's LINE OUT outputs can make the sound coming from external speakers sound more natural when playing with reverb active or when you are playing along with a pre-recorded piano CD. In some cases when you play along with a recording of the same instrument phase problems can occur causing significant loss of bass frequency, stereo image problems or cancellation of other frequencies. Simply inverting the phase of the outputs can improve or correct these problems.

Press the EQ button ten times. (If you selected USER EQ, press the EQ button thirteen times). The button will light and the display will show the following information.

LINE OUT PHASE INV      OFF
--------------------------------

Set the value with the "+ YES", "- NO" buttons. You can select (OFF, ON).

Play the piano while listening to the sound from the speakers. By switching the LINE OUT PHASE INVERT ON/OFF, you can easily invert output's phase (it inverts to left and right at the same time) and hear if there is any improvement in the sound quality coming from the speakers.

# 3. Reverb Button Menu

- \* Press REVERB button. The button will light and the various parameters in the EQ menu will be displayed.
- \* Press the REVERB button repeatedly to advance through the menu.
- \* To change the value for the selected parameter, use the “+ YES”, “– NO” buttons.
- \* When you are finished making your settings, press the BACK button to go back to main screen. The REVERB button light will turn off.

The following parameters are assigned to the EQ button.

- 1) PIANO MIC REVERB
- 2) PIANO MIC REVERB TYPE
- 3) LINE/MIC REVERB DEPTH
- 4) LINE OUT REVERB

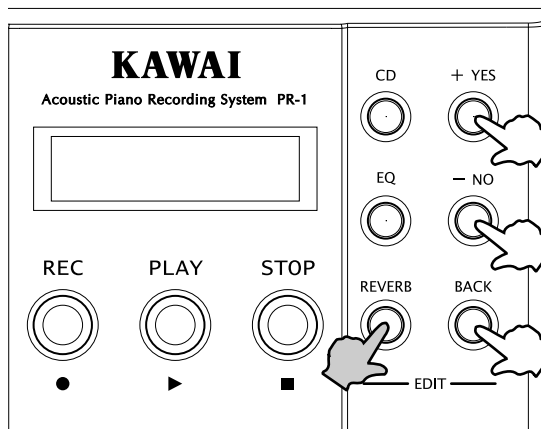

## 1) PIANO MIC REVERB

You can add reverb to the piano when you practice or record the piano to create the ambience of stage or concert hall. If you piano is located in a small room you can also simulate the feeling of playing in a concert hall by connecting an amplifier and external speakers and turning the reverb on.

Setting the reverb depth.

Press the REVERB button. The button will light and the display will show the following information.

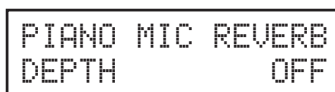

Set the value with the “+ YES”, “– NO” buttons. You can select the following reverb depth values (OFF, 1 – 10). OFF does not have any reverb. 10 would be the maximum depth.

## 2) PIANO MIC REVERB TYPE

Selects the type of reverb.

Press the REVERB button twice. The button will light and the display will show the following information.

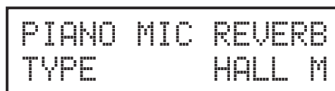

Set the value with the “+ YES”, “– NO” buttons. You can select the following reverb types.

HALL L ↔ HALL M ↔ HALL S ↔ ROOM L ↔ ROOM M ↔ ROOM S

HALL L/M/S simulates the ambience of a concert hall or theater. HALL L is the largest hall simulation. HALL M/S simulate progressively smaller halls.

ROOM L/M/S simulates the ambience of a living room or small rehearsal room. ROOM L is the largest room simulation. ROOM M/S simulate progressively smaller rooms.

### 3) LINE/MIC REVERB DEPTH

You can also add reverb to a microphone or instrument that is connected to the LINE/MIC IN inputs.

Press the REVERB button three times. The button will light and the display will show the following information.

```
LINE/MIC REVERB
DEPTH          OFF
```

Set the value with the “+ YES”, “– NO” buttons. You can select the following reverb depth values (OFF, 1 – 10). OFF does not have any reverb. 10 would be the maximum depth.

### 4) LINE OUT REVERB

There are times when recording that you connect an amplifier and external speaker to the LINE OUT outputs and want to add reverb to the piano. However you don't want to make the reverb too deep for the recording but you would like to hear more reverb from the speakers. LINE OUT REVERB allows you adjust the LINE OUT reverb ratio so it can be deeper without affecting your recording.

Press the REVERB button four times. The button will light and the display will show the following information.

```
LINE OUT REVERB
RATIO          0
```

Set the value with the “+ YES”, “– NO” buttons. The default setting is 0. When set to 0 the reverb depth for the recording and the LINE OUT would be the same. Setting minus values will make the LINE OUT reverb depth less than the recording and you will hear less reverb through the speakers. Setting positive values makes the LINE OUT reverb depth more than the recording and you will hear more reverb through the speakers. When the depth is set to OFF (when recording to a CD), no reverb is sent to the to LINE OUT or heard through the speakers.

# PR-1 APPLICATIONS GUIDE

## 1. Recording a Piano along with another instrument or vocalist using the MIC setting for the LINE/MIC inputs

Make sure that the piano microphones are connected correctly (see pg.8 & 36-40 for more detail).

- ① Connect a microphone to one of the LINE/MIC Jacks. MIC1, MIC2 either is okay.
- ② Switch the LINE/MIC switch to MIC.
- ③ Adjust the microphone's volume level with the LEVEL knob. Use the level indicator on the front panel to adjust the signal level for the best sound (see pg.14 for more detail). If necessary, adjust the LEVEL knob of the PIANO MIC IN (see pg.9 for more detail). Adjust the balance between the piano and microphone by listening with headphones.
- ④ If necessary, while listening with headphones adjust the microphone's left/right panning. You can set the panning of MIC1 and MIC2 individually (see pg.23, 24 for more detail).

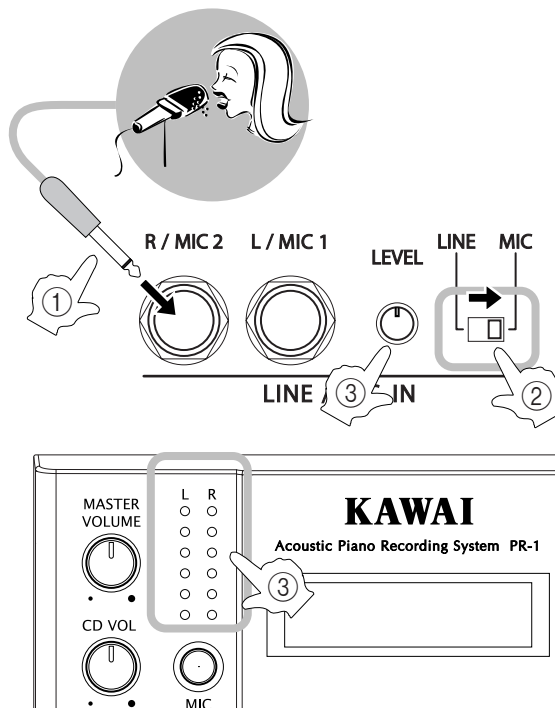

## 2. Recording a Piano along with another instrument or ensemble using the LINE setting for the LINE/MIC inputs Make sure that the piano microphones are connected correctly (see pg.8 & 36 - 40 for more detail).

- ① Connect the output from the instrument/s to the LINE/MIC IN.
- ② Switch the LINE/MIC switch to LINE.
- ③ Adjust the external instrument's volume level with the LEVEL knob. Use the level indicator on the front panel to adjust the signal level for the best sound (see pg.14 for more detail). If necessary, adjust the LEVEL knob of the PIANO MIC IN (see pg.9 for more detail). Adjust the balance between the piano and other instrument sounds by listening with headphones.
- ④ If necessary, while listening with headphones adjust the microphone's left/right panning. You can set the panning of MIC1 and MIC2 individually (see pg.23, 24 for more detail). When connecting stereo instruments such as an electronic keyboard, setting the panning to (LINE L = L10, LINE R = R10) will usually sound best. Please feel free to experiment.

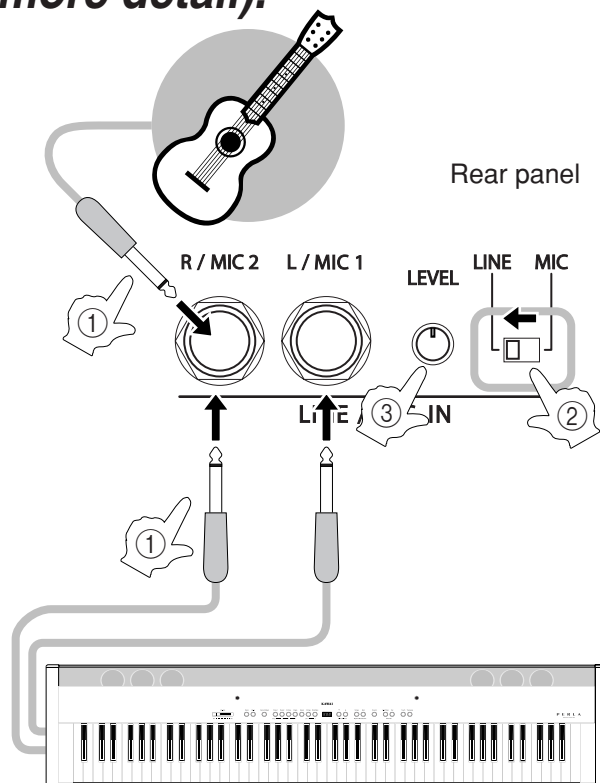

### 3. Recording a piano along with an External CD Player or Tape Recorder

Make sure that the piano microphones are connected correctly (see pg.8 & 36-40 for more detail).

- ① Connect the out put of the CD player or tape recorder to the LINE/MIC IN. If necessary, use a conversion adaptor because the PR-1's input jack is a normal 1/4" jack.
- ② Switch the LINE/MIC switch to LINE.
- ③ Adjust the CD player's volume level with the LEVEL knob. Use the level indicator on the front panel to adjust the signal level for the best sound (see pg.14 for more detail). If necessary, adjust the LEVEL knob of the PIANO MIC IN (see pg.9 for more detail). Adjust the balance between the piano and CD player by listening with headphones.
- ④ If necessary, while listening with headphones adjust the microphone's left/right panning. You can set the panning of MIC1 and MIC2 individually (see pg.23, 24 for more detail). Since a CD player is usually in stereo, setting the panning to (LINE L = L10, LINE R = R10) will usually sound best. Please feel free to experiment.

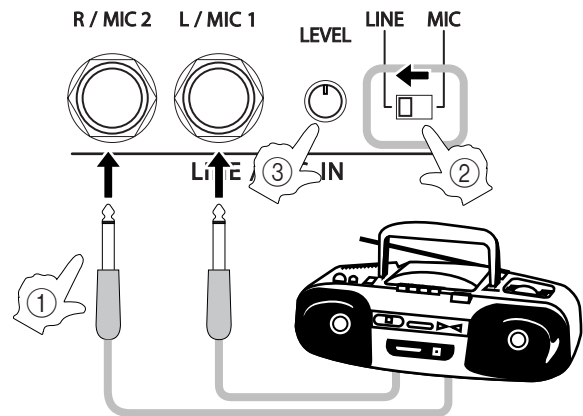

### 4. Recording a Piano in a concert hall

Let's suppose that you want to put the PR-1 on the side of the stage or backstage and record a piano concert using the extended length piano microphone cables (15 m) which are sold separately.

- ① Disconnect the standard piano microphone cables and connect the extended length cables (15 m).
- ② Attach the piano microphones to the piano. (see pg.8 & 36-40 for more detail).
- ③ Connect the microphone cables to the PR-1. See pg.8
- ④ If you want to add song numbers to the recording without stopping the recorder (to avoid missing any of the performance) please see pg.11 for more detail on adding song numbers while recording.
- ⑤ If you want to record the ambience of the audience (Applause etc.) you can connect another microphone to the LINE/MIC IN, facing towards the audience.

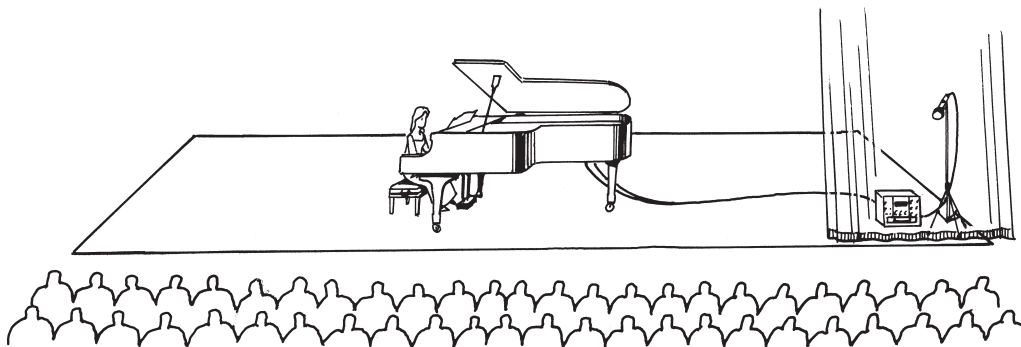

## 5. Recording a Piano using different Reverb settings

See pg.26 “REVERB button Menu” for more information on setting the reverb.

## 6. Adding reverb to an instrument connected to the LINE/MIC inputs when recording a song

See pg.27 “LINE/MIC Reverb Depth” for more detail.

## 7. Adjusting the sound character of a piano that you are recording using EQ

See pg.21 “Menu of EQ button” for more detail.

## 8. Using the PR-1 for live sound reinforcement.

Because the PR-1 microphones are designed specifically for an acoustic piano they make getting a good live sound for concerts or other performances very easy. The PR-1 can be connected to a PA system using the LINE OUT outputs. Both 1/4' and XLR jacks are provided. There is also a ground lift switch for the XLR jacks to help control ground loop noise.

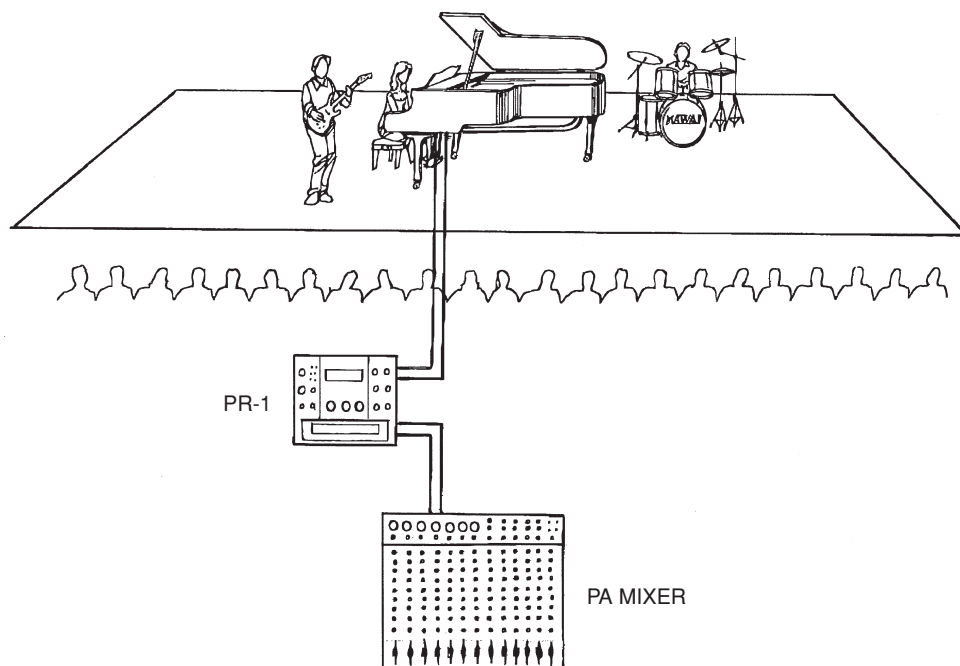

## 9. Using the PR-1 in the studio

Because the PR-1 microphones are specifically designed for an acoustic piano they can also be used as a recording microphone setup in a studio or other recording applications. The PR-1 can be connected to an external recorder or recording console using the LINE OUT outputs. Both 1/4' and XLR jacks are provided. There is also a ground lift switch for the XLR jacks to help control ground loop noise.

# PLAYING BACK A CD USING THE PR-1 OR AN EXTERNAL CD PLAYER

## 1. How to Play a CD

In addition to playing back recordings made on the PR-1 you can play commercially recorded CD-R, CD-RW, and CD's sold at stores using the PR-1.

### <CONNECTION>

Turn the POWER on (see pg.8).

Connect an amplifier and external speakers to the LINE OUT or connect a set of headphones to PHONES jack to listen.

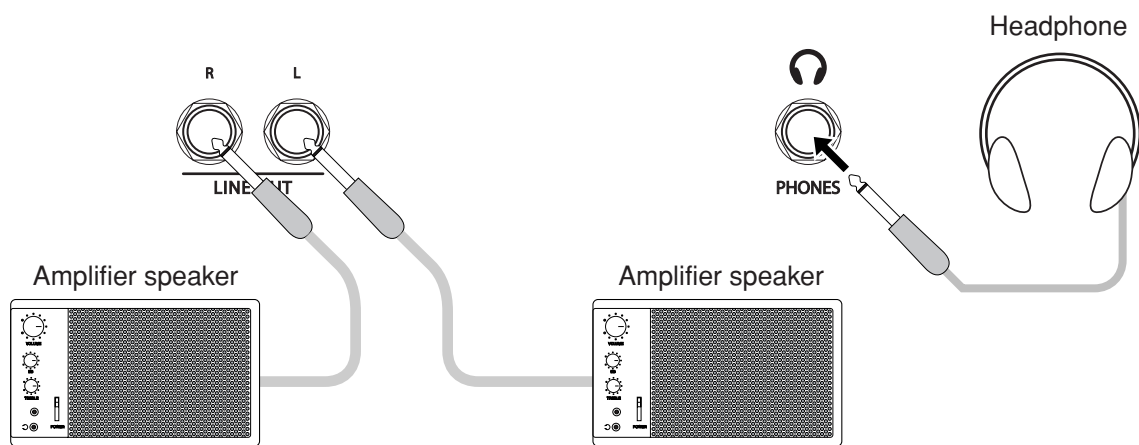

After making the necessary connections, turn the PR-1 on and insert the disc you want to play in the tray.

Press the SONG button and select the song number you want to play.

Press the PLAY button and the CD will start playing from the beginning of the desired song.

Press STOP button and the song will stop playing. (If you press the PLAY button again, it starts from where you stopped)

You can fast forward or rewind the song by pressing and holding the appropriate SONG button. Press the left SONG button to rewind and the right SONG button to fast forward

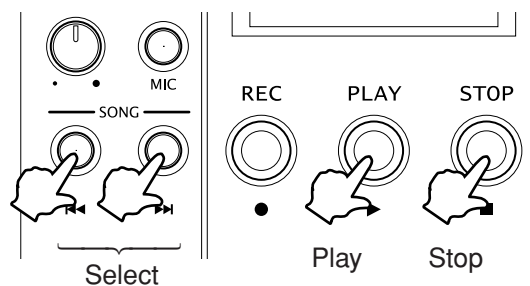

Note) On some CD's (like recording of live stage), the sound will be constant without any breaks and only the song number will change. If you play using the PR-1, when the song number changes, there will be slight space with no sound.

## 2. Other CD playback functions

### 1) HOW TO REPEAT 1 SONG

You can repeat playing back the song that is now selected or a song you have selected. (It keeps on playing until you press STOP button)

Press CD button seven times until you see REPEAT in the display. Use the “+ YES”, “– NO” buttons to select “ONE SONG” (see pg.20). Press the PLAY button and the selected song will be repeated.

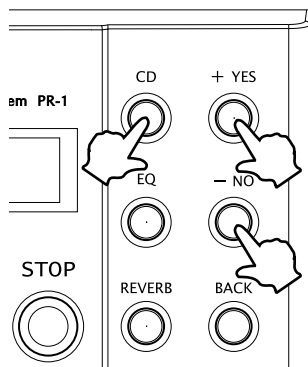

### 2) HOW TO REPEAT ALL SONGS ON A CD

You can repeat all of the songs on a CD repeatedly. (It keeps on playing until you press STOP button)

Press CD button seven times until you see REPEAT in the display. Use the “+ YES”, “– NO” buttons to select “WHOLE SONG” (see pg.20). Press the PLAY button and the PR-1 will keep on repeating all of the songs on the CD until you press the STOP button.

### 3) HOW TO ADJUST THE PITCH OF A CD

There may be times when it is useful to be able to adjust the pitch of the CD. This function is useful to match the tuning of a pre-recorded CD to the tuning of your piano. The PR-1 allows you to adjust the pitch of a CD.

Press CD button six times until you see CD PLAY PITCH in the display. Use the “+ YES”, “– NO” buttons to adjust the pitch by increasing and decreasing the value.

## 3. Playing a CD recorded using the PR-1 on an External CD Player

You can instantly play and listen to a CD you have just recorded using the PR-1. If you want to listen to the CD on another CD player or recordable CD radio cassette player, you need to FINALIZE the CD first.

Press CD button until you see FINALIZE in the display (see pg.7 or pg.17 for more detail). Use the “+ YES” button to finalize your CD. Remember that once you finalize a CD-R disc you cannot record any more on that disc. CD-RW discs can be unfinalized (see pg.7 or pg.17 for more information).

## 4. How to Enjoy Playing by Listening to a Comfortable Reverb

With the PR-1, you can hear the sound of the piano through external speakers or with headphones by using the piano microphones even if you are not recording. By adding reverb to the piano sound you can create the feeling of playing in a larger room or hall.

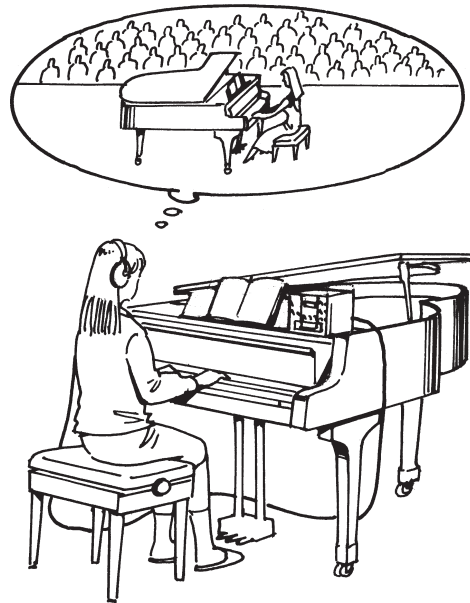

### <CONNECTION AND ADJUSTMENT>

Turn the POWER on (see pg.8).

Connect an amplifier and external speakers to the LINE OUT or connect a set of headphones to PHONES jack to listen.

Turn the POWER on .

To adjust the reverb settings See pg.26 “REVERB button Menu” for more detail.

When using external speakers, you can add more reverb depth to the speakers without changing the depth of the reverb when recording to a CD by adjusting the LINE OUT REVERB (see pg.27 for more detail).

Press EQ button to adjust the sound quality of piano. Select your favorite EQ setting by pressing “+ YES”, “- NO” button when selecting PIANO MIC TONE (see pg.21 for detail).

## **5. Practicing a Four-hand Performance using the PR-1 to record one of the parts**

You can practice playing a four-hand performance by first recording one of the parts to CD then playing along with the recording.

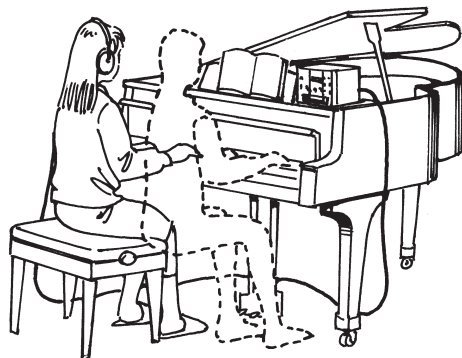

### **<CONNECTION AND ADJUSTMENT>**

Turn the POWER on as in pg.8.

Connect an amplifier and external speakers to the LINE OUT or connect a set of headphones to PHONES jack to listen.

Insert the CD that you used to record one of the parts of a four-hand performance and play the CD.

While playing, you can use the MASTER VOLUME knob and the CD VOL knob to adjust the balance between the live piano and the CD.

When you listen to the CD with headphones, do not turn off the piano microphones because you cannot hear your live performance properly without them. When using headphones only the player can hear the sound of the CD.

You must connect an amplifier and external speakers in order for others to listen to both parts.

## **6. Playing along with a Karaoke or music minus one CD**

You can enjoy playing along with karaoke CD's or music minus one CD's for piano using the PR-1. You can add reverb to your performance and to the CD as well. Experimenting with adding reverb to the piano or the CD can add to your enjoyment of performing with these types of CD's.

The connection and adjustments are same as the four-hand performance above. When using headphones only the player can hear the sound of the CD. You must connect an amplifier and external speakers in order for others to listen or perform with the CD.

## ***7. Recording other instruments using the PR-1.***

If you connect an instrument other than a piano to the LINE/MIC IN, you can easily record their performances to a CD just like the piano. You can also add reverb to the sound and play along with karaoke or music minus one CD's. Instruments like trumpet and flute need to use the LINE/MIC IN inputs with the MIC setting. If you don't have a microphone available, and you aren't recording the piano, the piano microphones can be used to record other instruments. (You will have to experiment to find the best microphone position for each type of instrument).

When you practice an instrument like trumpet or saxophone in a small soundproof room using the reverb through external speakers, try using two Microphones. Set one microphone facing the instrument and set its LINE/MIC IN panning to CENTER (see pg.23) and set the ANTI-FEEDBACK (see pg.24) to on to reduce the possibility of feedback when using an amplifier and speakers. Set the other microphone in the room away from the instrument. (see the illustration on this page).

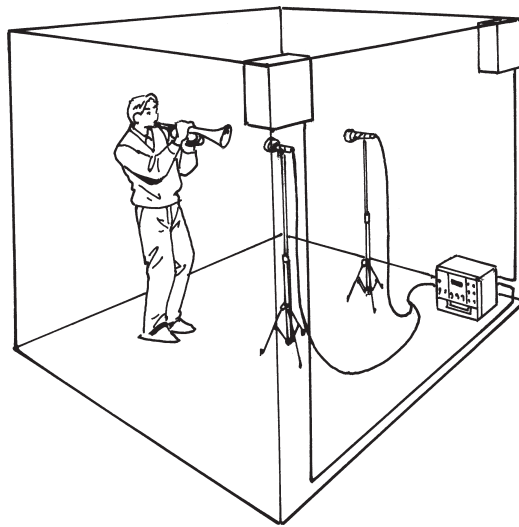

# CONNECTING THE PR-1 MICROPHONES TO A GRAND PIANO

Please attach each microphone to the piano according to the illustrations on this page. To get the best balance between the upper and lower key ranges please attach one microphone near the lower keys and close to the soundboard. Please attach the other microphone near the upper keys and farther away from the soundboard.

- ① Connect the piano microphones and piano microphone cables.

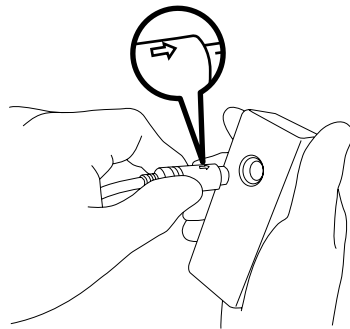

Make sure that the arrow is facing upward when connecting the cable to the microphone.

- ② When you look under a grand piano, you will see several beams on the bottom of the soundboard. Attach the supplied Mounting band to the beams according to the illustration. The piano microphones will be attached to these bands. Suggested mic placement guidelines for various Kawai grand pianos are listed on the following page (pg.37). These guidelines will be useful for getting a good, balanced recording.

(Do not wrap the band too tightly. If the band is too tight it may transmit vibrations from the piano to the microphone).

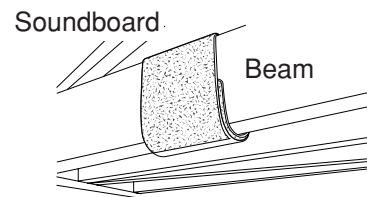

- ③ After you have attached the bands to the desired location on the beams, attach the piano microphone's fastening tape side to the band with the cable facing down according to the illustration.

If you want to prevent the loose sections of the cable from hanging down or lying on the floor, it is OK to place the cable on top of one of the beams.

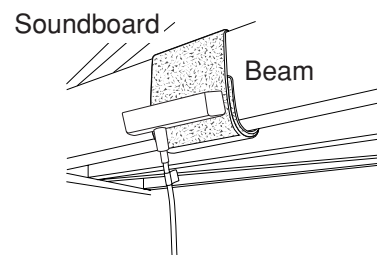

- ④ Connect the piano microphone cables to the PIANO MIC IN on the main unit. Connect the microphone for the lower keys to the left (L) jack and the microphone for the upper keys to the right (R) jack. It is helpful to put colored tape or some other marking on the cables so you can easily tell at a glance which is left and right.

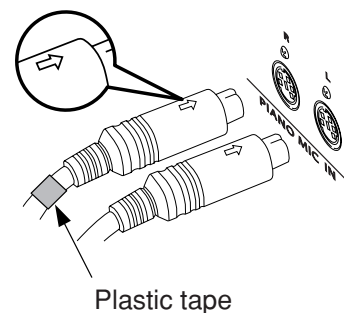

# MICROPHONE PLACEMENT GUIDE FOR VARIOUS KAWAI GRAND PIANOS

The following placement guidelines were developed specifically for the PR-1 piano microphones. Using other types of microphones with these guidelines may not produce a good result. If your piano is different from the models listed below just select the model that is the closest to your piano as a starting point.

The illustrations below are rough sketches of the beams, when looking at them from underneath a grand piano. The left side of the illustration shows the upper keys (right) and the right side shows the lower keys (left). Please be aware of this point when you connect the microphones.

This distance between the microphones and the soundboard should be approximately 7 cm for the left microphone (lower keys) and 12 cm for the right microphone (upper keys).

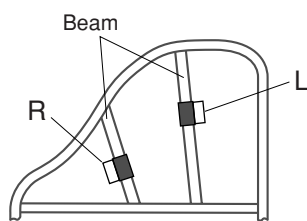

(150 cm)  
GM-10

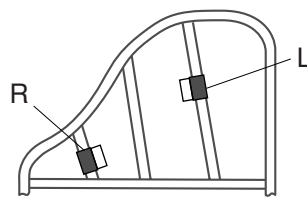

(154 cm)  
GE-20

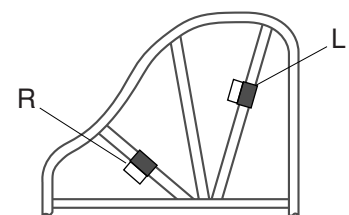

(164 cm)  
GE-30, KG-1N, KA-1  
KG-1E, RX-1G, RX-1A

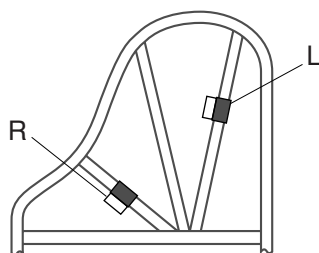

(178 cm)  
SK-2, KG-2N, KA-2, KG-2E  
KG-2D, RX-2G, RX-2A

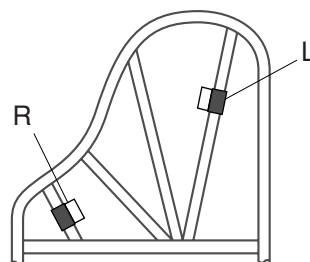

(186 cm)  
SK-3, GS-30, NX-40A, KG-3N,  
CA-40A, CR-40A, CR-40N,  
RX-3A, RX-3G,

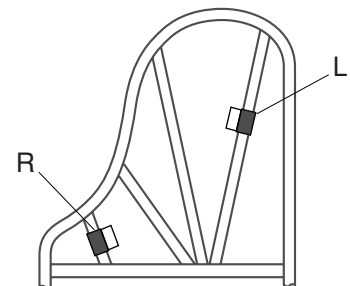

(197 cm)  
SK-5, RX-A, R-1, RX-5A  
RX-5G, NX-50A

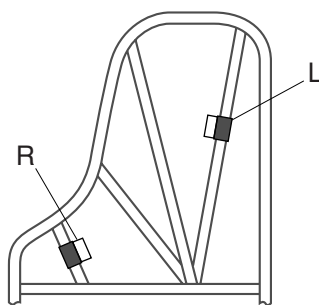

(212 cm)  
SK-6, RX-6G, RX-6A,  
RX-B, NX-60A

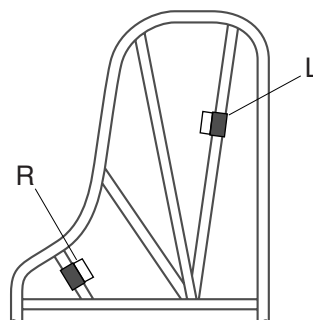

(227 cm)  
SK-7, RX-7A,  
RX-7G, CA-70A

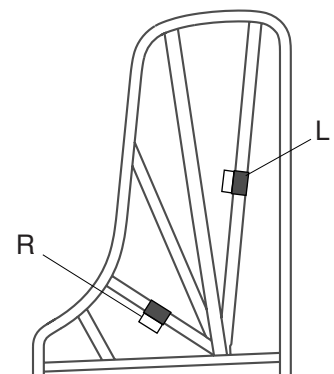

(276 cm)  
GS-100  
EX

If you feel that the sound of the upper keys is too strong, you can adjust the sound by moving the right microphone over one beam toward the lower keys or by increasing the distance between the soundboard and the microphone.

# CONNECTING THE PR-1 MICROPHONES TO AN UPRIGHT PIANO

Please attach each microphone to the piano according to the illustrations on this page. To get the best balance between the upper and lower key ranges please attach one microphone near the lower keys and close to the soundboard. Please attach the other microphone near the upper keys and farther away from the soundboard.

The exact position for the microphones will depend on where your piano is located in the room.

- \* If you can easily access the back of the piano, we prefer you attach the microphones on the back side.
- \* If it is difficult to access the back of the piano, we prefer you attach the microphones on the front bottom side of the frame (see pg.39 for detail on microphone placement).

- ① Connect the piano microphones and piano microphone cables.

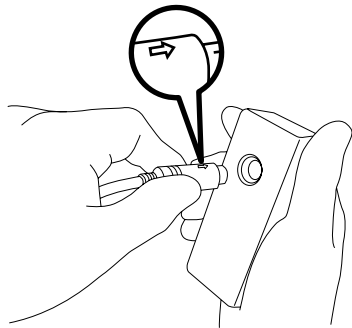

Make sure that the arrow is facing upward when connecting the cable to the microphone.

- ② When you look at the back side of an upright piano, you can see the back posts. Attach the supplied Mounting bands to the posts according to the illustration. The piano microphones will be attached to these bands. Suggested mic placement guidelines for Kawai upright pianos are listed on the following page (pg.39). These guidelines will be useful for getting a good, balanced recording.

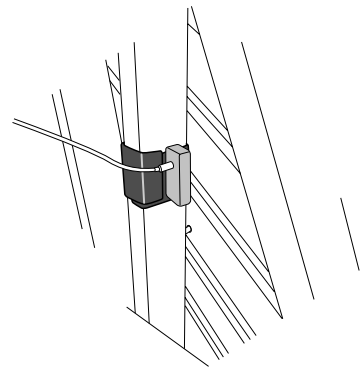

(Do not wrap the band too tightly. If the band is too tight it may transmit vibrations from the piano to the microphone).

- ③ After you have attached the bands to the desired location on the posts, attach the piano microphone's fastening tape side to the band with the cable facing down according to the illustration.
- ④ Connect the piano microphone cables to the PIANO MIC IN on the main unit. Connect the microphone for the lower keys to the left (L) jack and the microphone for the upper keys to the right (R) jack. It is helpful to put colored tape or some other marking on the cables so you can easily tell at a glance which is left and right.

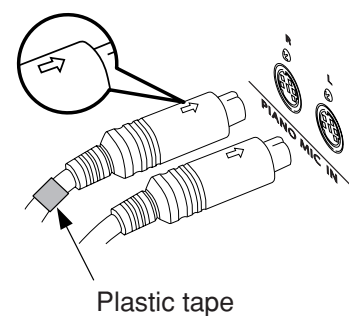

# MICROPHONE PLACEMENT GUIDE FOR KAWAI UPRIGHT PIANOS

The following placement guidelines were developed specifically for the PR-1 piano microphones. Using other types of microphones with these guidelines may not produce a good result

The illustrations below are rough sketches of the back posts on an upright piano, when looking at them from the back side. The left side of the illustration shows the upper keys (right) and the right side shows the lower keys (left). Please be aware of this point when you connect the microphones.

This distance between the microphones and the soundboard should be approximately 7 cm for the left microphone (lower keys) and 12 cm for the right microphone (upper keys).

Upright piano with 4 back posts

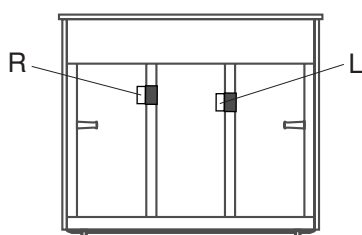

Upright piano with 5 back posts

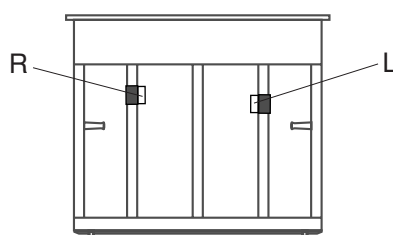

Upright piano with 6 back posts

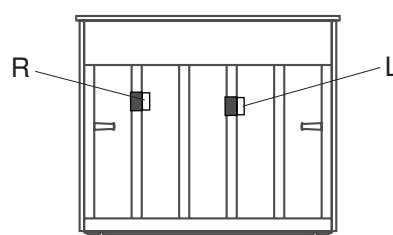

\* For a piano where it is either not practical or not possible to attach the microphones to the back of the piano, it is also possible to remove the lower front panel and attach the microphones to the iron plate struts:

① Connect the attached piano microphones to their respective cables.

② Removing the lower front panel.



**To prevent personal injury and potential damage to the piano, the lower front panel should be taken off with two people because the panel is quite heavy. If you find it difficult to remove the panel, please contact your local Kawai dealer or your piano tuner and ask for help**

②-1 Locate the retaining spring and the knob at the top of the lower panel. Push up on the spring while holding the knob to release the panel.

②-2 The lower panel can now be leaned out towards you. There are several dowels on the bottom of the lower panel which hold it into piano.

②-3 Hold on to the lower panel's bottom edge and lift up on the knob to remove it from the piano. Carefully and slowly, lift off the lower panel and place it in a safe place. After taking it off you can see the piano's strings and plate similar to the illustration below.

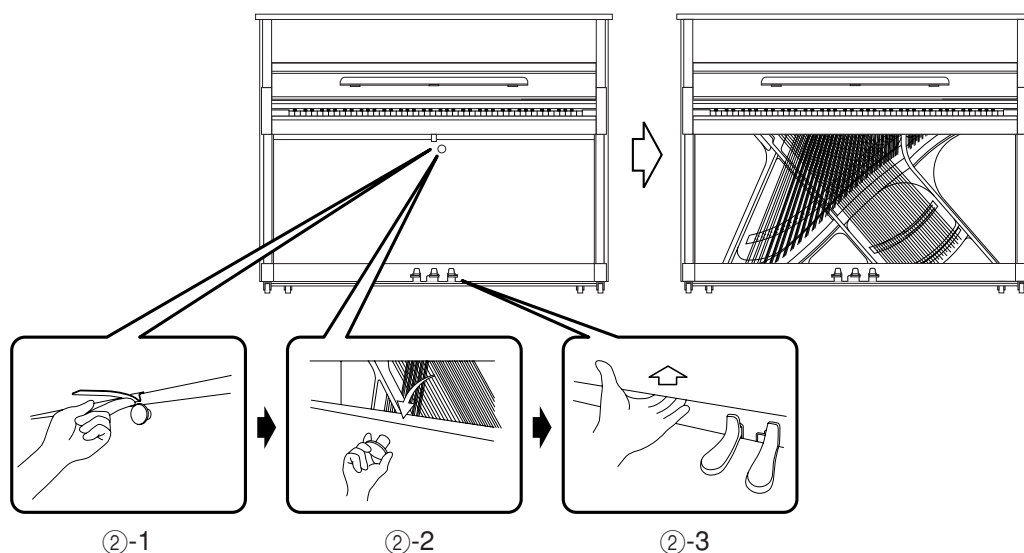

The place to attach the piano microphones is the same.

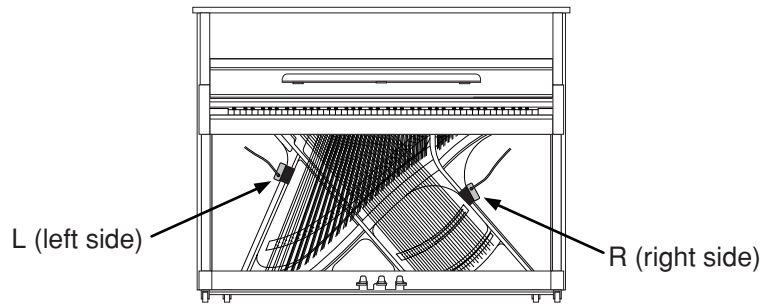

③ Attaching the piano microphones to the frame.

③-1 Attach the mounting bands to the thin steel frame on the left side. It is easier to attach the bands to the thinner frame if you fold it in half.

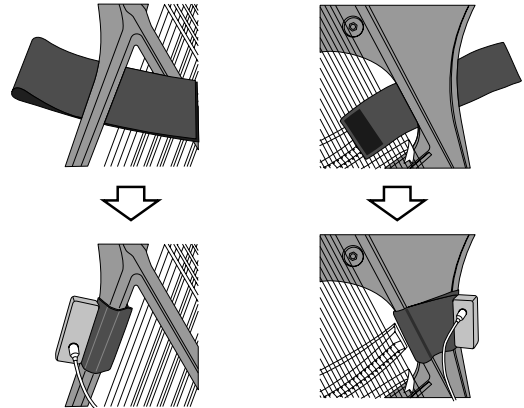

③-2 The frame on the right side is wider than the left side so it may be hard to attach the band. Look at the illustration on the right and attach the microphone.

④ Replace the lower panel. Position the microphone cables so that they pass over the top of the lower panel. First put back the dowel at the bottom edge of the lower panel into their holes, then tilt up the lower panel until the spring snaps into place. Most pianos will have a gap on the top of the lower panel for the microphone cables to pass - be careful not to pinch the cables when replacing the lower panel.

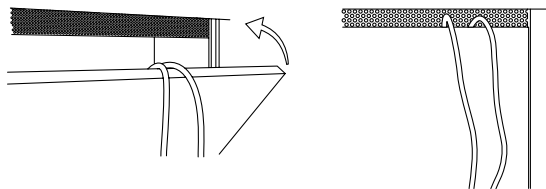

If there is not enough space for the cable to pass over the lower front panel, please call your local Kawai dealer, or ask your piano tuner to assist you.

⑤ Connect the piano microphone cables to the PIANO MIC IN on the main unit. Connect the microphone for the lower keys to the left (L) jack and the microphone for the upper keys to the right (R) jack. It is helpful to put colored tape or some other marking on the cables so you can easily tell at a glance which is left and right.

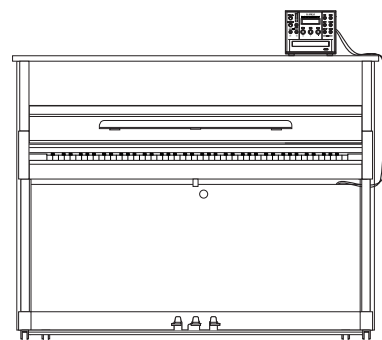
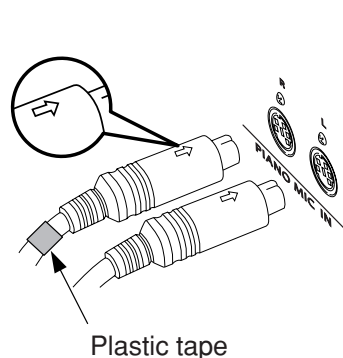

PR-1, set on the top of the piano

# TROUBLESHOOTING

Please use the guide to diagnose some common problems that might occur.

## 1. No sound from the external speakers when playing the CD

- \* Make sure the MASTER VOLUME knob is not set to 0.
- \* Make sure the CD VOLUME knob is not set to 0.
- \* Make sure the amplifier for the external speakers is turned ON.
- \* Make sure the volume of the external speakers is not set to 0.
- \* Make sure the connections between the PR-1's LINE OUT jacks and the speaker amplifier input are connected correctly.

## 2. When you cannot record

- \* Make sure that the CD-R or CD-RW disc you are using still has time available to record.
- \* Make sure the piano microphone LEVEL is set correctly
- \* The PR-1 cannot record songs shorter than 5 seconds. Please wait at least 5 seconds before you press the STOP button.
- \* Make sure the piano microphones or LINE/MIC INPUTS connections are correct.

## 3. The rotation speed of the CD drive gets fast and slow.

- \* This is normal and occurs when the CD drive is reading or writing information to and from the disc.

## 4. The recorded sound is distorted

- \* Make sure that the LEVEL indicator's red LED is not constantly lit.
- \* Adjust the microphone recording level by using the PIANO MIC IN LEVEL knob or LINE/MIC IN LEVEL knob so that the Red LED on the level indicator does not light up except with the loudest sounds.

## 5. The external speakers feedback when you add reverb to your piano

- \* This type of feedback will sometimes occur when the microphone picks up the sound coming out from the speaker. You can prevent the feedback by changing the position of the speaker. See pg.24, 25.

You can also use the ANTI-FEEDBACK and LINE OUT PHASE to control this type of feedback.

# SPECIFICATIONS

## [PR-1, Acoustic piano Recording System]

Microphone	2 microphones specifically designed for recording of pianos with built in Preamplifier.	
CD control functions	Music search, Fast forward/rewind, Record, Play, Stop, Repeat, CD pitch adjustment, Record start timer, Finalizing, Unfinalizing (CD-RW), Song delete (CD-RW)	
Reverberation setting	Reverberation type (room size) 6, Piano reverberation depth OFF to 10, Line/microphone-in reverberation depth OFF to 10, Line out reverberation adjustment	
EQ setting	Preset EQ10, User (3 band EQ), Line/microphone (2-band EQ), Pan-pot (piano, line/microphone independent), Noise gate (piano, line/microphone independent), Anti-feedback ON/OFF, Line out phase invert	
Control functions	Master volume, CD volume, Piano microphone switch, Piano microphone recording level control (L/R independent), Input level selection (line/microphone), External microphone/line input level control	
Input/output jacks	Piano microphone input	2 jacks (L/R) for PR-1 piano microphones
	Line in	2 jacks (L/R), line/microphone selection
	Line out	2 jacks (L/R)
	XLR out	
	Fixed level	
	Foot switch	For start/stop
	Headphone	1 jack
Others	Recording level indicator, Japanese/English display selectable	
Power	DC IN (15 V DC 1.5 A) Please use only the supplied AC adaptor with the PR-1.	
Accessories	Piano microphone (2 microphones), Piano microphone cable (2 3 m-long cables), Attachment band for the piano microphones (2 bands), CD-RW (blank one for recording), AC adapter, Instruction Manual	
Dimensions/weight	18.0 (W) x 22.5 (D) x 16.2 (H) (cm) / 2.7 kg	

## Optional Accessories

Foot switch (F-1M)

Extended length piano microphone cable (15 m)

Headphones







**KAWAI**

Printed in Indonesia

815411

KPSZ-0131